

HILTI

DD 200

Bedienungsanleitung

Operating instructions

Mode d'emploi

Istruzioni d'uso

Gebruiksaanwijzing

Manual de instruções

Manual de instrucciones

Οδηγίες χρήσεως

de

en

fr

it

nl

pt

es

el



305560

CE

1

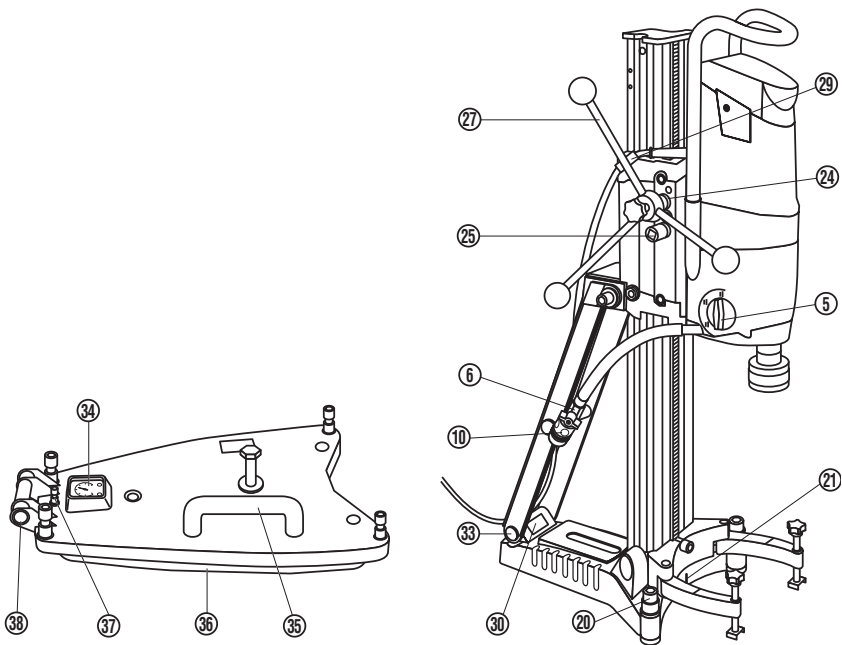
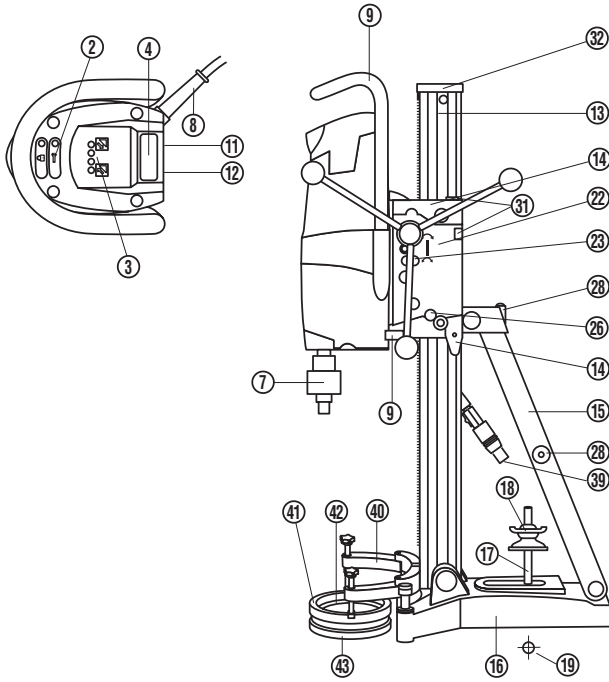

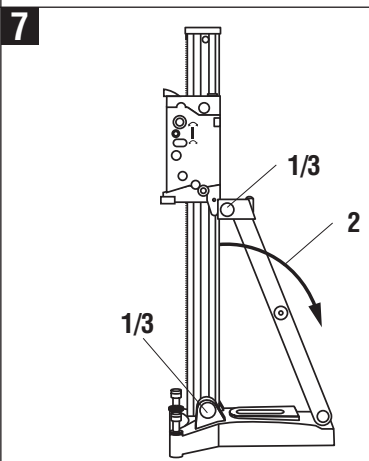
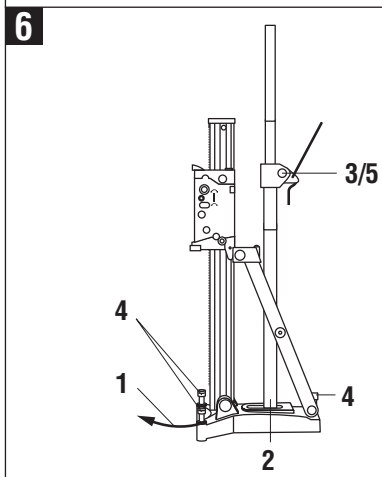
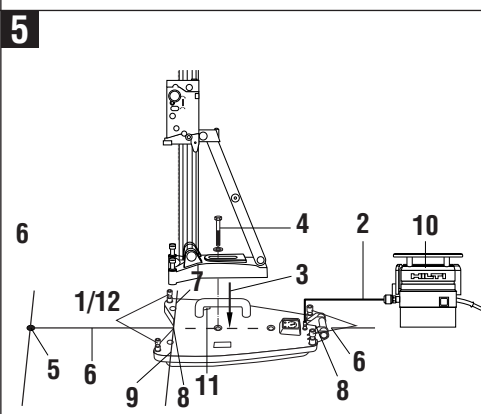
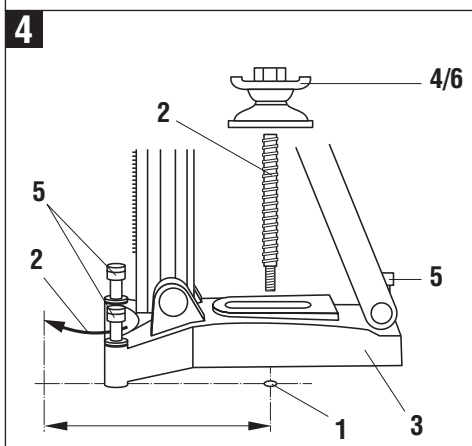
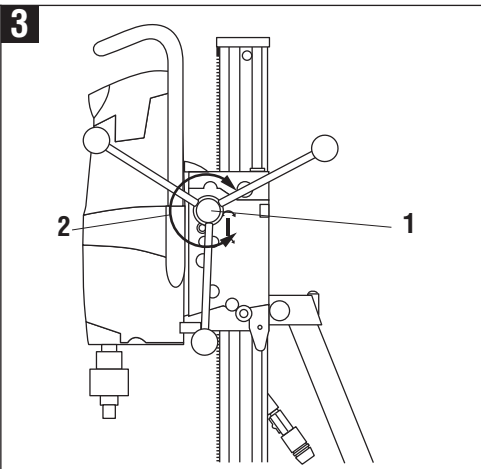
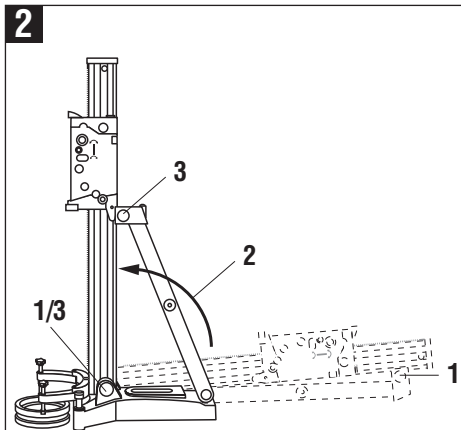

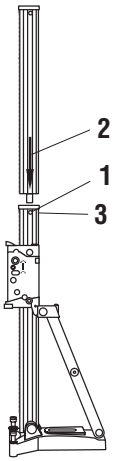
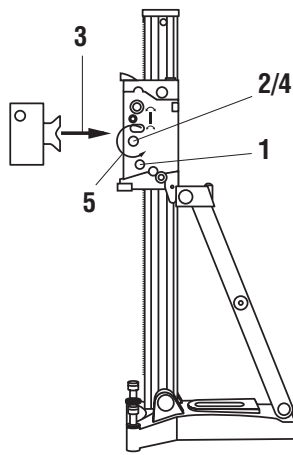
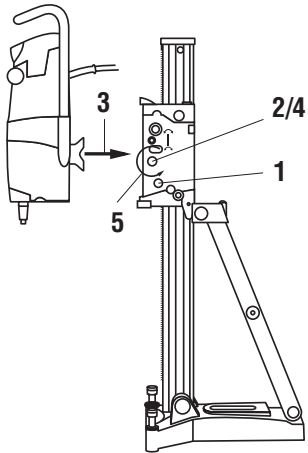
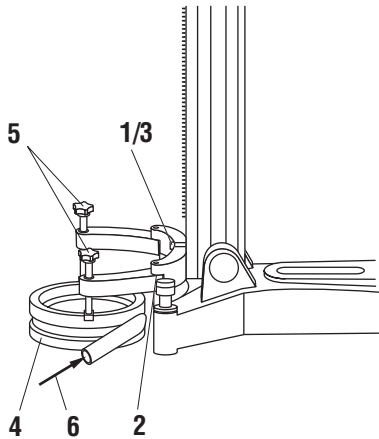
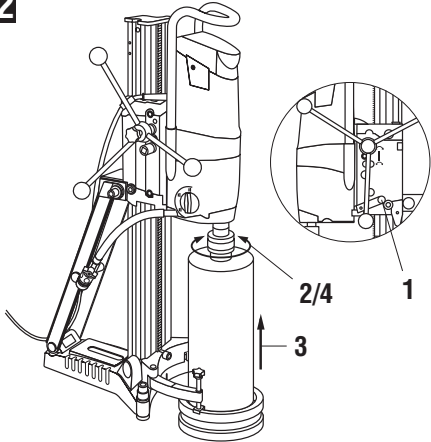
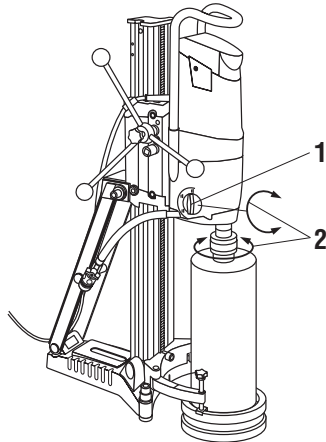
8**9****10****11****12****13**

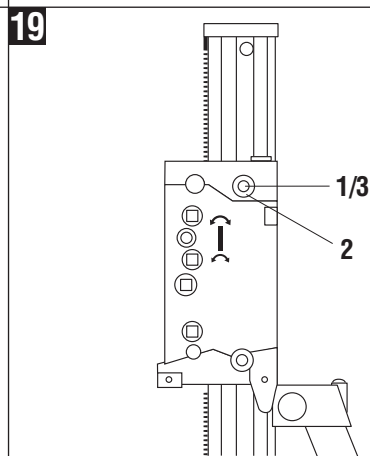
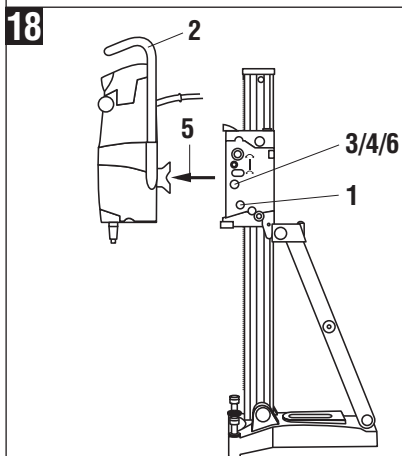
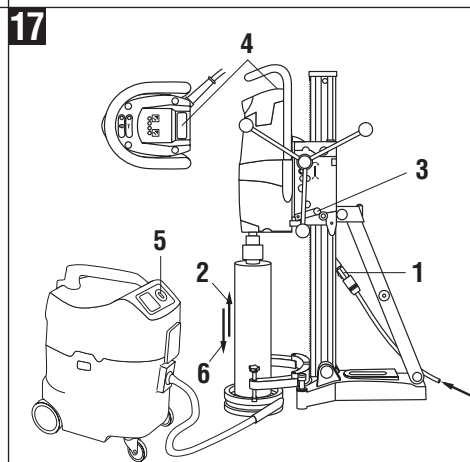
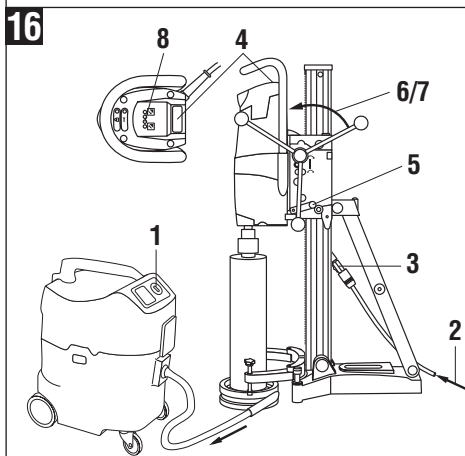
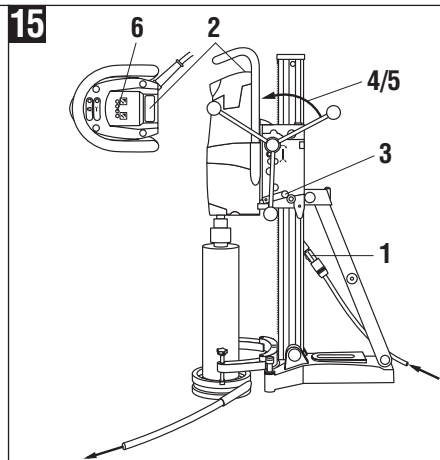
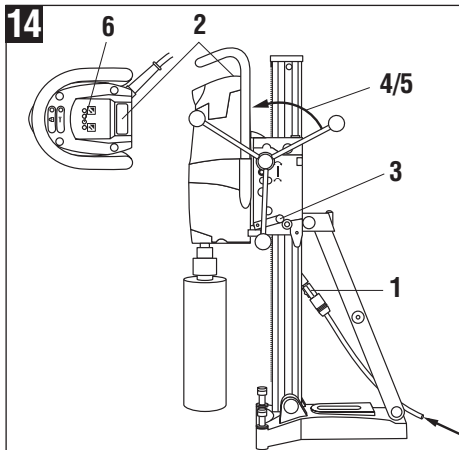

DD 200 diamond core drilling system

It is essential that the operating instructions are read before the machine is operated for the first time.

Always keep these operating instructions together with the machine.

Ensure that the operating instructions are with the machine when it is given to other persons.

Operating controls, parts and indicators Drilling rig (drive unit and drill stand)

Drive unit

- ② Service indicator
- ③ Drilling performance indicator
- ④ On / off switch
- ⑤ Gear selector switch
- ⑥ Water flow regulator
- ⑦ Chuck
- ⑧ Supply cord with PRCD
- ⑨ Carrying grips (2)
- ⑩ Water hose connector
- ⑪ Type plate
- ⑫ Interface

Drill stand

- ⑬ Column
- ⑭ End cap
- ⑮ Strut
- ⑯ Base plate
- ⑰ Clamping spindle
- ⑱ Clamping nut
- ⑲ Anchor

- ⑳ Leveling screws
- ㉑ Hole center indicator
- ㉒ Carriage
- ㉓ Drive unit (eccentric) locking bolt
- ㉔ Direct drive
- ㉕ Reduction gear
- ㉖ Carriage locking mechanism
- ㉗ Hand wheel
- ㉘ Carrying grip
- ㉙ Supply cord guide
- ㉚ Type plate
- ㉛ Leveling indicators (2)
- ㉜ End stop
- ㉝ Wheel assembly mounting point

ACCESSORIES

Vacuum base plate

- ㉞ Pressure gauge
- ㉟ Vacuum release valve
- ㊱ Vacuum seal
- ㊲ Vacuum hose connector
- ㊳ Wheel assembly mounting point

Water flow indicator

- ㊴ Water flow indicator

Water collector system

- ㊵ Water collector holder
- ㊶ Water collector
- ㊷ Seal
- ㊸ Seal

Column extension

- ㊹ Eccentric bolt

Depth gauge

Spacer

- ㊺ Drive unit locking mechanism

Wheel assembly

- ㊻ Set of wheels

| Contents | Page |
|----------------------------------|------|
| 1. General information | 15 |
| 2. Description | 17 |
| 3. Tools and accessories | 17 |
| 4. Technical data | 17 |
| 5. Safety precautions | 18 |
| 6. Before use | 20 |
| 7. Operation | 23 |
| 8. Care and maintenance | 25 |
| 9. Troubleshooting | 26 |
| 10. Disposal | 27 |
| 11. Warranty | 28 |
| 12. EC declaration of conformity | 28 |

1. General information

1.1 Safety notices and their meaning

-DANGER-

Draws attention to imminent danger that could lead to serious bodily injury or fatality.

-CAUTION-

Draws attention to a potentially dangerous situation that could lead to slight personal injury or damage to the equipment or other property.

-NOTE-

Draws attention to instructions and other useful information that help the user to employ the product efficiently.

1.2 Pictograms

Prohibition signs



Transport by crane is not permissible.

en

Warning signs



General warning



Warning: electricity



Warning: hot surface

Symbols



Read the operating instructions before use.



Recycle waste material

On the vacuum baseplate

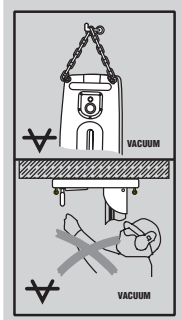

Top:
An additional means of securing the drill stand must be employed when used for horizontal drilling with vacuum attachment.

Below:
Use of only the vacuum baseplate to secure the drill stand for overhead drilling is not permissible.

On the tool



Use of the water collector system in conjunction with a wet-type vacuum cleaner is mandatory when working overhead on ceilings.

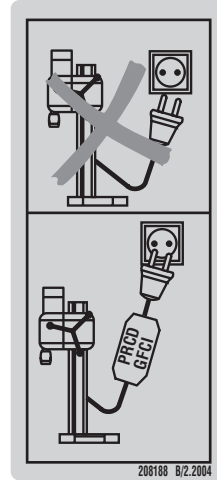

Use of a correctly functioning PRCD circuit breaker is mandatory.

1 These numbers refer to the corresponding illustrations. The illustrations can be found on the fold-out cover pages. Keep these pages open while studying the operating instructions. In these operating instructions, the designation "the machine" refers to the DD 200 core drilling machine.

Location of identification data on the machine

The type designation and serial number can be found on the rating plate on the machine. Make a note of this data in your operating instructions and always refer to it when making an enquiry to your Hilti representative or service department.

Type: DD 200

Serial no.: _____

Type: DD-HD 30

Serial no.: _____

2. Description

2.1 Use of the equipment as intended

The DD 200 and DD HD-30 form a drilling rig designed for wet core drilling in mineral materials using diamond core bits (hand-held use is not permissible). The drive unit must always be mounted on the drill stand when in use and the drill stand secured adequately by means of an anchor, vacuum base plate or quick-release brace. Manipulation or modification of the drive unit, drill stand or accessories is not permissible. To avoid the risk of injury, use only original Hilti accessories and insert tools. Observe the information printed in the operating instruc-

tions concerning operation, care and maintenance. Observe the safety precautions and operating instructions for the accessories used. Do not use a hammer or other heavy object when making adjustments to the baseplate. The drive unit, drill stand, accessories and insert tools may present hazards when used incorrectly by untrained personnel or not as directed. The machine may be operated only when connected to an adequately rated electric supply equipped with an earth / ground conductor.

en

| Equipment | Core bits | Drilling direction |
|--|----------------|--------------------|
| System with water collector and wet-type vacuum cleaner | 25–250 mm dia. | All directions |
| System without water collector and wet-type vacuum cleaner | 25–400 mm dia. | Not upwards |
| System with water collector | 25–250 mm dia. | Not upwards |

Use of the water collector system in conjunction with a wet-type vacuum cleaner is mandatory when working overhead on ceilings. Use of the quick-release brace is not permissible for working on ceilings.

Horizontal drilling in conjunction with the vacuum base plate (accessory) is permissible only when an additional means of securing the drill stand is employed. Drilling into materials hazardous to the health (e.g. asbestos) is not permissible.

3. Accessories

| | |
|------------------------|---------------------|
| Water flow indicator | 305939 |
| Depth gauge | 305535 |
| Water collector holder | 305536 |
| Column extension | 305537 |
| Vacuum base plate | 305538 |
| Vacuum pump | 332158; 92053 (USA) |
| Spacer | 305539 |
| Wheel assembly | 305541 |
| Clamping spindle | 305940 |
| Clamping nut | 251834 |
| Quick-release brace | 9870 |
| Water collector 25-162 | 232221 |
| Water collector 92-250 | 232243 |
| Water collector 8-87 | 232204 |

4. Technical data

| Drive unit | DD 200 | | | | | |
|--|--------------|----------|--------------|----------|----------|----------|
| Rated voltage* | 100 V | 110 V | 220 V | 230 V | 230 V | 240 V |
| Rated power input* | | 2300 W | 2500 W | 2600 W | 2600 W | |
| Rated current* | 15 A | | | | | |
| Rated frequency | 50/60 Hz | 50/60 Hz | 50/60 Hz | 50/60 Hz | 50/60 Hz | 50/60 Hz |
| Nominal speed under no load (r.p.m.) | 380/640/1300 | | 320/550/1120 | | | |
| Max. permissible water supply pressure | 6 bar | | | | | |

| | |
|--------------------------------------|-------------------------------|
| Dimensions (LxWxH) | 630x150x173 mm |
| Weight (drive unit) | 12.7 kg |
| Weight (drill stand) | 17.9 kg |
| Drilling depth | max. 500 mm without extension |
| Protection class as per EN/IEC 61029 | protection class I (earthed) |

Noise and vibration information (measured in accordance with EN 61029-1):

| | |
|--|------------|
| Typical A-weighted noise power level (L _{WA}): | 105 dB (A) |
| Typical A-weighted noise emission pressure level (L _{pA}): | 92 dB (A) |

Wear ear protection

| | |
|---|------------------------|
| Typical weighted vibration at the hand wheel: | < 2,5 m/s ² |
| Interference immunity | as per EN 55014-2 |
| Radio and television interference suppression | as per EN 55014-1 |

* The machine is available in several versions with different voltage ratings. Please refer to the type plate for the voltage rating and input power rating of your machine.

5. Safety precautions

CAUTION: The following basic safety precautions must always be observed when using electric machines in order to avoid the risk of electric shock, injury or fire.

Read all of these instructions before using this machine and keep this list of safety precautions for future reference.

5.1 The necessary safety precautions at the workplace



- Approval must be obtained from the site engineer or architect prior to beginning drilling work. Drilling work on buildings and other structures may influence the statics of the structure, especially when steel reinforcing bars or load-bearing components are cut through.
- Ensure that the workplace is well lit.
- Ensure that the workplace is well ventilated.
- Keep the workplace tidy. Objects which could cause injury should be removed from the working area. Untidiness at the workplace can lead to accidents.
- When drilling through-holes, the area below the ceiling, floor or behind the wall where the drilling is taking place must be secured as the drilled-out core may fall out.
- Use clamps or a vice to secure the workpiece. The workpiece is thus held more securely than by hand and both hands remain free to operate the machine.
- Use protective equipment. Wear eye protection.
- Wear breathing protection if the work creates dust.
- Wear suitable working clothing. Do not wear loose clothing, loose long hair or jewelry as it can become caught up in moving parts. Wear suitable headgear if you have long hair.
- It is recommended that rubber gloves and non-slip shoes are worn when working outdoors.
- Keep children and other persons away from the working area.
- Do not allow other persons to tamper with the machine or the supply cord.
- Avoid unfavorable body positions. Work from a secure stance and stay in balance at all times.
- To avoid tripping and falling when working, always lead the supply cord, extension cord and water hose away to the rear.
- Keep the supply cord, extension cord, water hose and vacuum hose away from rotating parts of the machine.
- **CAUTION: Before beginning drilling, check that there are no live electric cables located in the area where the hole is to be made.**
- Concealed electric cables or gas and water pipes present a serious hazard if damaged while you are working. Accordingly, check the area in which you are working beforehand (e.g. using a metal detector). External metal parts of the machine may become live, for example, when an electric cable is drilled into inadvertently.
- Do not work from a ladder.

5.2 General safety precautions



- Use the right machine for the job. Do not use the machine for purposes for which it was not intended. Use the machine only as directed and when it is in faultless condition.
- Use only the original accessories or ancillary equipment listed in the operating instructions. Use of other insert tools or accessories may present a risk of personal injury.
- Take the influences of the surrounding area into account. Do not expose the machine to rain or snow and do not use it in damp or wet conditions. Do not use the machine where there is a risk of fire or explosion.
- Keep the grips dry, clean and free from oil and grease.
- Do not overload the machine. It will work more efficiently and more safely within its intended performance range. The side handle must be fitted for all types of work.
- Never leave the machine unattended.
- When not in use, the machine must be stored in a dry place, locked up or out of reach of children.
- Avoid unintentional starting. Check that the on / off switch is in the "off" position before plugging the supply cord into the electric socket.
- Unplug the machine from the electric supply when it is not in use, during pauses between work, before maintenance and when changing core bits.
- Check the PRCO each time before use.
- Take care of your core bits. You will be able to work more efficiently and more safely if the core bits are kept sharp and clean.
- Check the machine for possible damage. Protective devices and any parts that may have suffered slight damage should be checked for correct operation and functionality before further use. Check that moving parts function correctly without sticking and that no parts are damaged. All parts must be fitted correctly and fulfill all conditions necessary for correct operation of the machine. Damaged safety devices or other damaged parts must be replaced or repaired properly by an authorized repair workshop unless otherwise indicated in the operating instructions.
- Avoid skin contact with drilling slurry.
- Wear respiratory protection when the work creates dust, e.g. during dry drilling. Connect a vacuum cleaner to the drilling system. Drilling into materials that present a health hazard (e.g. asbestos) is not permissible.

5.2.1 Mechanical hazards



- Follow the instructions concerning care and maintenance.

- Check that the insert tools used are compatible with the chuck system and that they are secured in the chuck correctly.
- Make sure that the machine is correctly and securely attached to the drill stand.
- Do not touch rotating parts.
- Make sure that all clamping screws are tightened correctly.
- After detaching the column extension, the end cap (with built-in, safety-relevant end stop function) must be refitted to the drill stand.

5.2.2 Electrical hazards



- Protect yourself against electric shock. Avoid body contact with earthed / grounded objects, e.g. pipes, radiators, cookers and fridges.
- Check the condition of the supply cord and its plug connections and have it replaced by a qualified electrician if damage is found. Check the condition of the extension cord and replace it if damage is found.
- Check the condition of the machine and its accessories. Do not operate the machine or its accessories if damage is found, if the machine is incomplete or if its controls cannot be operated faultlessly.
- Do not touch the supply cord in the event of it suffering damage while working. Disconnect the supply cord plug from the socket.
- Damaged or faulty switches must be replaced at a Hilti service center. Do not use the machine if it cannot be switched on and off correctly.
- Have the machine repaired only by a trained electrical specialist (Hilti service center) using original Hilti spare parts. Failure to observe this point may result in risk of accident to the user.
- Do not use the supply cord for purposes for which it is not intended. Never carry the machine by the supply cord and never pull the plug out of the socket by pulling the supply cord.
- Do not expose the supply cord to heat, oil or sharp edges.
- When working outdoors, use only extension cords that are approved and correspondingly marked for this application.
- In the event of a power failure, switch the machine off and unplug the supply cord.
- Avoid using extension cords with multiple sockets and the simultaneous use of several machines connected to one extension cord.
- Never operate the machine when it is dirty or wet. Dust (especially dust from conductive materials) or dampness adhering to the surface of the machine may, under unfavorable conditions, cause an electric shock to be received. Dirty or dusty machines should thus be checked at a Hilti service center at regular intervals, especially used frequently for working on conductive materials.

5.2.3 Thermal hazards



- The core bit may become hot during use. Wear protective gloves when changing core bits.

5.3 Requirements to be met by users

- The machine is intended for professional use.
- The machine may be operated, serviced and repaired only by authorized, trained personnel. This personnel must be informed of any special hazards that may be encountered.
- Always concentrate on the job you are doing. Proceed carefully and do not use the machine if your full attention is not on the job.
- Exercise your fingers during pauses between work to improve blood circulation in your fingers.

5.4 Personal protective equipment

- The user and any other persons in the vicinity must wear suitable eye protection, a hard hat, ear protection, protective gloves and safety footwear while the machine is in use.



Wear eye protection



Wear a hard hat



Wear ear protection



Wear protective gloves



Wear safety boots

6. Before use



-NOTE-

The mains voltage must correspond with the information printed on the type plate. Ensure that the machine is disconnected from the electric supply.

6.1 Use of extension cords

Use only extension cords of a type approved for the application and with conductors of adequate cross section. Recommended minimum conductor cross section and max. cable lengths

| Mains voltage | Conductor cross section | | | | | |
|-------------------------|-------------------------|-----------------|-----------------|------|-----------------|-------|
| | 1.5 mm ² | 2.0 | 2.5 | 3.5 | AWG | |
| Conductor cross section | 1.5 | 2.0 | 2.5 | 3.5 | 14 | 12 |
| 100 V | not permissible | not permissible | not permissible | 25 m | not permissible | – |
| 110–120 V | not permissible | not permissible | 20 m | – | not permissible | 75 ft |
| 220–240 V | 30 m | – | 50 m | – | – | – |

Do not use extension cords with 1.25 mm² or 16 AWG conductor cross sections.

6.2 Use of a generator or transformer

This machine may be powered by a generator or transformer which fulfils the following conditions:

- AC voltage, output power at least 4000 VA
- The operating voltage must be within +5% and –15% of the rated voltage at all times.

- Frequency range 50 – 60 Hz, never above 65Hz
- Automatic voltage regulation with starting boost

Never operate other machines or appliances from the generator or transformer at the same time. Switching other machines or appliances on and off may cause undervoltage and / or overvoltage peaks, resulting in damage to the machine.

6.3 Preparations

-CAUTION-

- The machine, the diamond core bit and the drill stand are heavy. There is a risk of pinching parts of the body. Wear a hard hat, protective gloves and safety boots.

6.3.1 Setting up the drill stand 2

-NOTE-

If the drill stand has been folded up to facilitate transport, proceed as follows:

1. Release the screws at the top end of the strut and at the column pivot.
2. Pivot the column into the vertical position (as far as it will go).
3. Tighten the screw at the top end of the strut and at the column pivot securely.

-NOTE-

The end cap must be fitted on the end of the column. It serves as a protector and as the end stop.

6.3.2 Fitting the hand wheel **3**

-NOTE-

The hand wheel can be fitted on the left or right side of the carriage, on either of the two axles. The upper axle drives the carriage directly while the lower axle drives the carriage by way of reduction gearing.

1. Fit the hand wheel to one of the two axles on either the left or right side of the carriage.
2. Secure the hand wheel with the screw provided.

6.3.3 Fastening the drill stand with an anchor **4**

1. Set an HKD-E M16 metal anchor 330 mm / 13" (the ideal distance) from the center of the hole to be drilled.
2. Screw the clamping spindle (accessory) into the anchor.
3. Position the drill stand over the spindle and bring it into alignment with the aid of the hole center indicator. When the spacer is used (accessory), the hole center indicator cannot be used to align the drill stand.
4. Screw the clamping nut onto the spindle but do not tighten it.
5. Level the base plate by way of the three leveling screws. The two level indicators on the carriage serve as a leveling aid.
6. Use a 27 mm AF open-end wrench to tighten the clamping nut on the spindle. Alternatively, the rear leveling screws can be tightened. The strut can be pivoted out of the way to facilitate access.
7. Check that the drill stand is fastened securely.

6.3.4 Fastening the drill stand with the vacuum base plate (accessory) **5**



-CAUTION-

Suitable for use only with core bits of up to 300 mm diameter and without use of a spacer.

-NOTE-

The hand grip on the vacuum base plate is equipped with a vacuum valve which can be used to release the vacuum.

Overhead drilling with the drill stand secured only by the vacuum base plate is not permissible.

1. Turn the four leveling screws back until they project approx. 5 mm beneath the vacuum base plate.
2. Connect the hose between the vacuum base plate and the vacuum pump.
3. Position the drill stand on the vacuum base plate.
4. Fit the screw and washer provided.
5. Mark the center point of the hole to be drilled.
6. Draw a line approximately 800 mm in length from the center mark toward the approx. position at which the drill stand is to be secured.
7. Make a mark on the 800 mm line at a distance of 165 mm (6½") from the hole center mark.

8. Bring the marks on the vacuum base plate into alignment with the 800 mm line.

9. Position the center of the front edge of the vacuum base plate on the line at the 165 mm (6½") mark.

-NOTE- Before using the vacuum pump, make yourself familiar with the information contained in its operating instructions and observe these instructions.

10. Switch on the vacuum pump and press the vacuum release valve.
11. Once the drill stand has been positioned correctly, remove your finger from the vacuum release valve and press the base plate against the work surface.

-CAUTION- Ensure that the pressure gauge pointer remains within the green area before beginning drilling and during the drilling operation.

12. Use the four leveling screws to level the vacuum base plate. The 2 built-in level indicators on the carriage serve as leveling aids. Note: Do not attempt to level the anchor base plate on the vacuum base plate. This is not permissible.
13. An additional means of securing the drill stand must be employed when drilling horizontally (e.g. a chain attached to an anchor, ...)
14. Check that the drill stand is fastened securely.

6.3.5 Securing the drill stand with a quick-release brace (access.: e.g. for use between floor and ceiling) **6**

1. Extend the hole center indicator and then use it as an aid to bring the drill stand into alignment with the center point of the hole to be drilled.
2. Position the end of the quick-release brace carefully between the two struts on the baseplate.
3. Secure the baseplate provisionally by applying slight pressure with the quick-release brace.
4. Level the baseplate by way of the 3 leveling screws. The 2 spirit levels on the carriage plate serve as leveling aids.
5. Tighten the quick-release brace securely.

6.3.6 Adjusting the angle of the drill stand (adjustable to max. 45°) **7**

-CAUTION-

Take care to avoid pinching your fingers at the pivot. Wear protective gloves.

1. Release the screw at the pivot at the lower end of the column and at the strut at the top end.
2. Bring the column into the desired position. The angle scale on the rear serves as an adjustment aid.
3. Retighten the two screws securely.

6.3.7 Using the column extension (accessory) **8**

1. Remove the end cap (with built-in end stop) from the top end of the column and refit it to the end of the column extension.
2. Fit the cylindrical section of the column extension into the end of the column on the drill stand.

en

- Secure the column extension by tightening the eccentric locking bolt.
- A depth gauge (accessory) may be fitted on the column as an additional end stop.
- The end cap (with built-in end stop) must be refitted to the column on the drill stand when the column extension is subsequently removed. The end stop is a safety-relevant part and must always be used.

6.3.8 Fitting the spacer (accessory) 9

-NOTE-

The distance between the drilling axis and the drill stand must be increased by fitting the spacer when diamond core bits with a diameter greater than 300 mm are to be used. The hole center indicator cannot be used in conjunction with the spacer.

These instructions presume that the drive unit is not already fitted.

- Lock the carriage in position on the column (activate the carriage locking mechanism).
- Release the drive unit locking bolt.
- Pull out the locking bolt.
- Fit the spacer onto the carriage.
- Push the locking bolt into the carriage as far as it will go.
- Tighten the locking bolt securely.

6.3.9 Mounting the drive unit on the drill stand 10

-NOTE-

Ensure that the drive unit is disconnected from the electric supply.

- Lock the carriage in position on the column (activate the carriage locking mechanism).
- Pull out the drive unit locking bolt.
- Fit the drive unit onto the carriage or spacer.
- Push the locking bolt into the carriage or spacer as far as it will go.
- Tighten the locking bolt securely.
- Clip the supply cord into the supply cord guide on the carriage cover.
- Check that the drive unit is mounted securely.

6.3.10 Connecting the water supply

- Close the water flow regulator on the drive unit.
- Connect the water supply hose to the hose connector.

-NOTE-

A water flow indicator (accessory) can be connected between the water supply hose and the hose connector on the drive unit.

-CAUTION-

Check the hoses for damage at regular intervals and ensure that the maximum permissible water supply pressure of 6 bar is not exceeded.

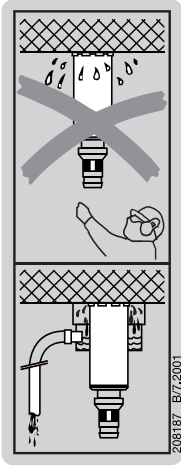

6.3.11 Fitting the water collector system (accessory) 11

-NOTE-

Use of the water collection system permits water to be drained away from the core bit thus avoiding soiling the surrounding area. We recommend use of the water collector system with core bits of up to 250 mm. diameter. Best results are achieved in conjunction with a wet-type vacuum cleaner.

Use of the water collection system in conjunction with a wet-type vacuum cleaner is mandatory for overhead drilling. The drill stand must be set up at 90° to the ceiling. The water collector seal must be of a size suitable for the core bit diameter used.

- Release the screw on the drill stand (at the front lower end of the column).
- Slide the water collector holder into place behind the screw from below.
- Tighten the screw securely.
- Fit the water collector between the two moveable arms of the water collector holder.
- Secure the water collector by way of the two screws on the water collector holder.
- Connect the water collector to a wet-type vacuum cleaner. Alternatively, the water can be allowed to flow away through a length of hose attached to the connector.

6.3.12 Adjusting the depth gauge (accessory)

- Turn the hand wheel until the core bit contacts the material in which the hole is to be drilled.
- Set the desired drilling depth by adjusting the distance between the carriage and the depth gauge.
- Secure the depth gauge by tightening the clamping screw.

6.3.13 Fitting a diamond core bit (drive unit with Hilti BL chuck)



– The core bit may become hot during use or during sharpening. It may burn your hands. Wear protective gloves when changing the core bit.

1. Lock the carriage in position on the column (activate the carriage locking mechanism) and check that the drill stand is fastened securely.
2. Open the chuck by turning it in the direction of the "open" symbol (open brackets).
3. Push the connection end of the diamond core bit into the chuck on the drive unit from below until it engages with the gear teeth.
4. Close the chuck by turning it in the direction of the "closed" symbol (closed brackets).
5. Check that the diamond core bit is held securely (check by hand for play and try to pull it away from the chuck).

6.3.14 Selecting drilling speed

-CAUTION-

Do not change gear while the motor is running. Wait until rotation has stopped.

1. Select the gear according to the core bit diameter to be used.
2. Move the gear selector switch to the desired setting while rotating the core bit by hand.

6.4 Transport



-CAUTION-

Transport the drive unit, drill stand and diamond core bit as separate units.

Use the wheel assembly (accessory) to facilitate transport.

7. Operation



-CAUTION-

- The machine and the core drilling operation emit noise. Excessive noise may damage the hearing. Wear ear protection.
- The core drilling operation may cause hazardous fragments to fly off. Flying fragments may cause injury to the eyes or other parts of the body. Wear eye protection and a hard hat.

7.1 Switching on and checking the PRCD ground fault interrupter

(use an isolating transformer with the GB version)

1. Plug the drive unit supply cord into an electric socket with earth connection.
2. Press the "ON" button on the PRCD ground fault interrupter (the indicator must light).
3. Press the "TEST" button on the PRCD ground fault interrupter (the indicator must go out).
4. Press the "ON" button on the PRCD ground fault interrupter (the indicator must light).

7.2 Core bit diameters and corresponding gears

| Gear | Core bit diameter | Speed under no load |
|------|--|---------------------|
| 1 | 202–400 mm / 8" – 16" | 320 r.p.m. |
| 2 | 102–182 mm / 4" – 7" | 550 r.p.m. |
| 3 | 25– 97 mm / 1" – 3 ³ / ₄ " | 1120 r.p.m. |

7.3 Operating the drilling machine without the water collector system and wet vacuum cleaner

-NOTE-

The water flows away in uncontrolled fashion. Overhead drilling is not permissible!

-CAUTION-

Do not allow water to come into contact with the drive unit.

7.3.1 Switching on

1. Open the water flow regulator slowly until the desired volume of water is flowing.
2. Press the on / off switch on the drive unit (switch position "I").
3. Release the carriage lock.
4. Turn the hand wheel until the core bit comes into contact with the material in which the hole is being drilled.
5. Apply only light pressure until the core bit has become centered and then gradually increase the pressure.

6. Regulate the pressure applied to the core bit by observing the drilling performance indicator (optimum drilling performance is achieved when the green lamps in the display light).

7.4 Operating the drilling machine with the water collector system (accessory)

-NOTE-

The water is allowed to flow away through a length of hose. Overhead drilling is not permissible!

-CAUTION-

Do not allow water to come into contact with the drive unit.

7.4.1 Switching on 15

1. Open the water flow regulator slowly until the desired volume of water is flowing.
2. Press the on / off switch on the drive unit (switch position "I").
3. Release the carriage lock.
4. Turn the hand wheel until the core bit comes into contact with the material in which the hole is being drilled.
5. Apply only light pressure until the core bit has become centered and then gradually increase the pressure.
6. Regulate the pressure applied to the core bit by observing the drilling performance indicator (optimum drilling performance is achieved when the green lamps in the display light).

7.5 Operating the drilling machine with the water collector system and wet-type vacuum cleaner (accessories)

-NOTE-

Drilling at an angle in an upwards direction is not permissible (the water collector is not functional). The core bit fills with water during overhead drilling.

-CAUTION-

Water must not be allowed to run over the drive unit.

-NOTE-

The wet-type vacuum cleaner must be switched on manually before beginning drilling and switched off manually at the end of the drilling operation.

7.5.1 Switching on 16

1. Switch on the wet-type vacuum cleaner. Do not use automatic mode.
2. Ensure that the water supply is connected and ready for use.
3. Open the water flow regulator.
4. Press the on / off switch on the drive unit (switch position "I").
5. Release the carriage lock.
6. Turn the hand wheel until the core bit comes into contact with the material in which the hole is being drilled.
7. Apply only light pressure until the core bit has become centered and then gradually increase the pressure.

8. Regulate the pressure applied to the core bit by observing the drilling performance indicator (optimum drilling performance is achieved when the green lamps in the display light).

7.6 Switching off 17

1. Close the water flow regulator.
2. Withdraw the diamond core bit from the hole.
Caution: The core bit fills with water during overhead drilling. After overhead drilling, the water must first be allowed to drain from the core bit. This is done by disconnecting the water supply hose from the connector on the drive unit and then opening the water flow regulator valve (do not allow the water to flow back through the water flow indicator). The water must not be allowed to run over the drive unit.
3. Engage the carriage lock.
4. Switch off the drive unit.
5. Switch off the vacuum cleaner, if used.
6. To ensure that the drill stand remains in balance, lower the core bit until in contact with the working surface or fold out the hole center indicator (this is not effective if using the vacuum baseplate).
7. If necessary, remove the core from the core bit.

7.7 Removing the drive unit from the drill stand 18

-NOTE-

Ensure that the machine is disconnected from the mains supply.

1. Secure the carriage on the column by engaging the carriage lock.
2. Hold the drive unit securely with one hand on the carrying grip. **-CAUTION-** The drive unit may otherwise fall from the drill stand!
3. Release the drive unit eccentric locking bolt with the other hand.
4. Pull out the eccentric locking bolt.
5. Remove the drive unit from the carriage.
6. Push the eccentric locking bolt back into the carriage as far as it will go.

7.8 Disposing of drilling slurry

see Section 10 "Disposal".

8. Care and maintenance

Disconnect the supply cord plug from the socket.

Care of insert tools and metal parts

Remove any dirt adhering to the core bits and protect their surfaces from corrosion by rubbing them with an oily cloth from time to time.

8.1 Care of the machine

The outer casing of the drive unit is made from impact-resistant plastic.

Never operate the drive unit when the ventilation slots are blocked. Clean the ventilation slots carefully using a dry brush. Do not permit foreign objects to enter the interior of the drive unit. Clean the outside of the drive unit at regular intervals with a cloth. Do not use a spray, steam pressure cleaning equipment or running water for cleaning. This may negatively affect the electrical safety of the drive unit.

8.2 Maintenance

Check all external parts of the machine for damage at regular intervals and check that all controls operate faultlessly. Do not operate the machine if parts are damaged or when the controls do not function faultlessly. If necessary, the machine should be repaired at a Hilti repair center.

Repairs to the electrical section of the machine may be carried out only by trained electrical specialists.

8.3 Replacing the carbon brushes

The indicator lamp with the wrench symbol lights when the carbon brushes require to be replaced.



Failure to observe the following instructions may present a possibility of coming into contact with a dangerous high voltage. The machine may be operated, serviced and repaired only by authorized, trained personnel. This personnel must be informed of any special hazards that may be encountered.

1. Disconnect the drive unit from the electric supply.
2. Remove the covers from the right and left sides of the drive unit.
3. Remove the used carbon brushes from the drive unit. Note how the brushes are fitted.
4. Fit the new carbon brushes exactly as the old carbon brushes (Spare part no.: 100–127 V: 279526; 220–240 V: 280097).
5. Screw the covers back on to the right and left sides of the machine.

8.4 Adjusting play between the column and the carriage 19

The play between the column and the carriage can be adjusted by way of 4 eccentrically-mounted rollers.

The 4 rollers shown in the illustration can be adjusted. First remove the drive unit from the drill stand and run the carriage up to the top of the column by turning the hand wheel. The 4 rollers can then be adjusted as follows:

1. Use a 5 mm AF hex. socket wrench to unscrew the locking screw slightly (do not remove the screw).
2. Use a 19 mm AF open-end wrench to turn the eccentric axle, thus pushing the roller slightly toward the column.
3. Tighten the locking screw.

8.5 Checking the equipment after care and maintenance

All functions must be checked after care and maintenance.

en

9. Troubleshooting

| Fault | Possible cause | Remedy |
|--|--|--|
| The machine doesn't start | Fault in the electric supply | Plug in another electric appliance and check whether it works. Check the plug connections, electric supply, PRCD and mains fuse. |
| | Supply cord or plug defective | Have it checked by a trained electrical specialist and replaced if necessary. |
| | Switch defective | Have it checked by a trained electrical specialist and replaced if necessary. |
| | Machine switched off by the automatic cut-out carbon brushes | Have it checked by a trained electrical specialist and replaced if necessary. |
| The motor runs but the core bit doesn't rotate | Gearing defective | Have the machine repaired at a Hilti service center. |
| | Gear selector switch not engaged | Move the gear selector switch until it is felt to engage. |
| Rate of drilling progress decreases | Water pressure / water flow rate too high | Reduce the flow with the water flow regulator. |
| | Core sticks inside the diamond core bit | Remove the core. |
| | Maximum drilling depth reached | Remove the core and use a core bit extension. |
| | Diamond core bit defective | Check the core bit for damage and replace it if necessary. |
| | Gearing defective | Have the machine repaired at a Hilti service center. |
| | Diamond core bit segments polished | Sharpen the core bit on a sharpening plate with water running. |
| | Diamond core bit segments polished | The wrong core bit specification has been used. Seek advice from Hilti. |
| | The slip clutch releases prematurely or slips permanently | Have the machine repaired at a Hilti service center. |
| The motor cuts out | The machine stops running | Reduce the pressure applied. |
| | Electronics defective | Have the machine repaired at a Hilti service center. |
| | Electric power failure | Check the plug connections, electric supply, PRCD and mains fuse. |
| | Cooling fan defective | Have the machine repaired at a Hilti service center. |
| | Carbon brushes worn | Have the machine repaired at a Hilti service center. |
| Water leakage at the water swivel or gear housing | Shaft seal defective | Have the machine repaired at a Hilti service center. |
| | Water pressure too high | Reduce the water pressure. |
| The diamond core bit cannot be fitted into the chuck | Chuck or connection end dirty or damaged | Clean the connection end / chuck or replace if necessary. |
| Water leakage at the chuck during operation | Chuck or connection end dirty | Clean the connection end / chuck.n |
| | Core bit not screwed securely into the chuck | Tighten it securely. |
| | Chuck seal or core bit connection end defective | Check the seal and replace it if necessary. |

| | | |
|---------------------------------------|---|---|
| Excessive play in the drilling system | Screw at the top end of the strut and / or at the column pivot point is loose | Tighten the screws. |
| | Core bit not screwed securely into the chuck | Tighten it securely. |
| | Drive unit locking mechanism loose | Tighten the drive unit locking mechanism. |
| | Leveling screws or clamping spindle not tightened | Retighten the leveling screws clamping spindle. |
| | Excessive play at the carriage | Adjust the play at the carriage guide rollers. |
| | Excessive play at the chuck | Check that the chuck runs true and replace it if necessary. |
| | Connection end defective | Check the connection end and replace it if necessary. |

10. Disposal



Most of the materials from which Hilti tools or machines are manufactured can be recycled. The materials must be correctly separated before they can be recycled. In many countries, Hilti has already made arrangements for taking back your old machines or tools for recycling. Please ask your Hilti customer service department or Hilti sales representative for further information.

Disposal of drilling slurry

With regard to environmental aspects, allowing drilling slurry to flow directly into rivers, lakes or the sewerage system without suitable pre-treatment is problematical. Ask the local authorities for information about applicable regulations.

We recommend the following pre-treatment:

Collect the drilling slurry (e.g. use a wet-type industrial vacuum cleaner).

Allow the slurry to settle and dispose of the solid material at a construction waste disposal site (the addition of a flocculent may accelerate the settling process).

Water from the drilling slurry (alkaline, pH value > 7) should be neutralized by adding an acidic neutralizing agent or large quantity of water before it is allowed to flow into the sewerage system.



Only for EU countries

Do not dispose of electric tools together with household waste material!

In observance of European Directive 2002/96/EC on waste electrical and electronic equipment and its implementation in accordance with national law, electric tools that have reached the end of their life must be collected separately and returned to an environmentally compatible recycling facility.

11. Warranty

en

Hilti warrants that the product supplied is free of defects in material and workmanship. This warranty is valid as long as the product is operated and handled correctly, cleaned and serviced properly and in accordance with the Hilti operating instructions, all warranty claims made within 6 months (machine) or 12 months (other items of equipment) from the date of the sale (invoice date), unless other mandatory national regulations prescribe a longer minimum period, and the technical system is maintained. This means that only genuine Hilti consumables, components and spare parts may be used with the product.

This warranty provides the free-of-charge repair or replacement of defective parts only. Parts requiring repair or replacement as a result of normal wear and tear are not covered by this warranty.

Additional claims are excluded, unless stringent national rules prohibit such exclusion. In particular, Hilti is not obligated for direct, indirect, incidental or consequential damages, losses or expenses in connection with, or by reason of, the use of, or inability to use the product for any purpose. Implied warranties of merchantability or fitness for a particular purpose are specifically excluded.

Send the product and/or related parts immediately upon discovery of a defect to the local Hilti marketing organization for repair or replacement.

This constitutes Hilti's entire obligation with regard to warranty and supersedes all prior or contemporaneous comments and oral or written agreements concerning warranties.

12. EC declaration of conformity

| | |
|-----------------|-------------------------|
| Designation: | Diamond drilling system |
| Type: | DD 200 |
| Year of design: | 2003 |

We declare, on our sole responsibility, that this product complies with the following standards or standardization documents: 98/37/EC, 89/336/EEC, EN 55014-1, EN 55014-2, EN 61000-3-2, EN 61000-3-3, EN 61029-1.

Hilti Corporation



Dr. Ivo Celi
Senior Vice President
Business Unit Diamond
12/2004



Dr. Heinz-Joachim Schneider
Executive Vice President
Business Area Electric Tools & Accessories
12/2004



Hilti Corporation

FL-9494 Schaan

Tel.: +423 / 234 21 11

Fax: +423 / 234 29 65

www.hilti.com