

# HILTI

Hilti Corporation  
 LI-9494 Schaan  
 Tel.: +423 / 234 21 11  
 Fax: +423 / 234 29 65  
 www.hilti.com

5.962-430

Hilti = registered trademark of Hilti Corp., Schaan W 3472 0408 00-Pos. 3 1 Printed in Germany © 2008  
 Right of technical and programme changes reserved S. E. & O.

224938 / B



# HILTI

## VC 40 / VC 20

Operating instructions	en
Mode d'emploi	fr
Manual de instrucciones	es
Manual de instruções	pt



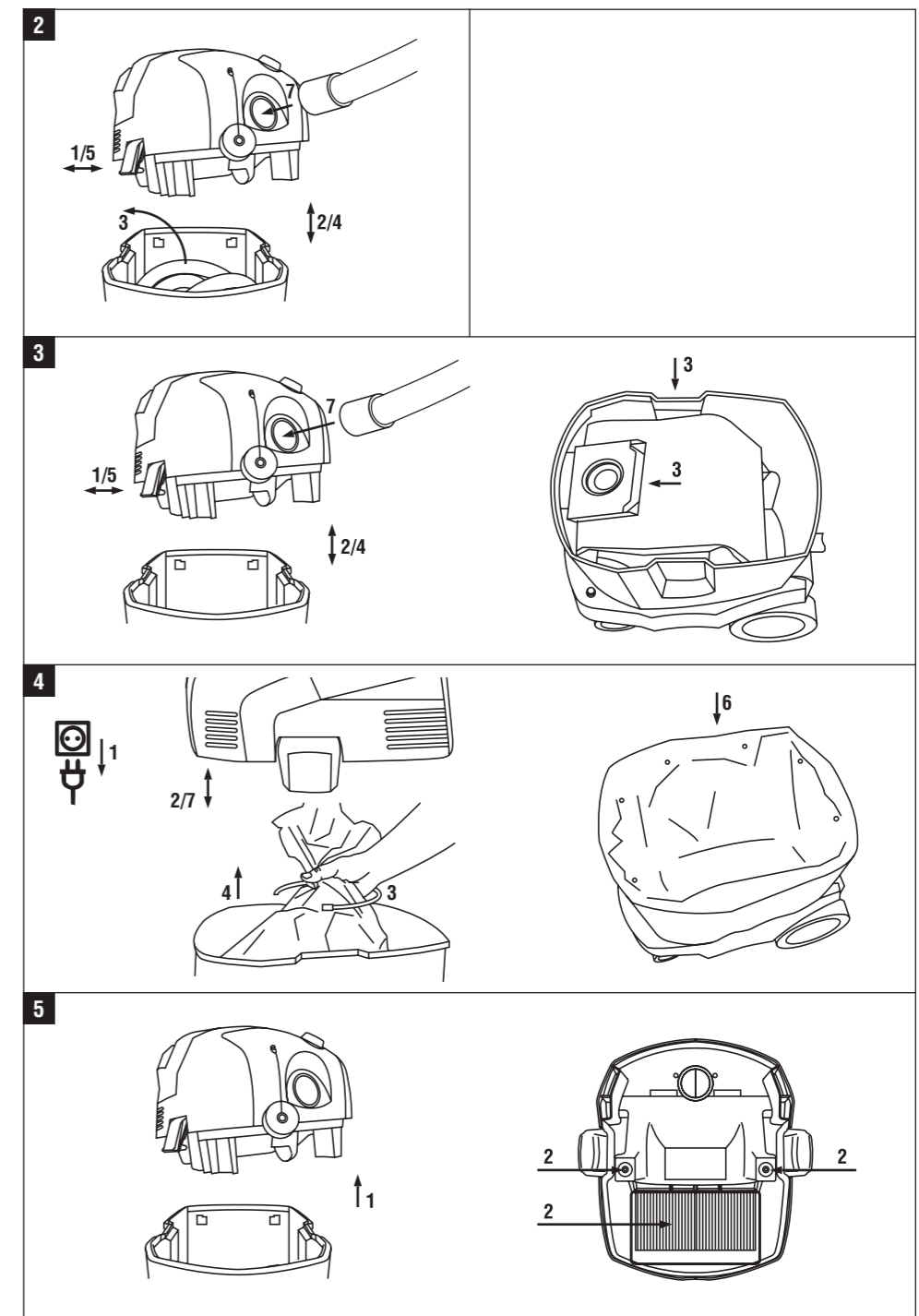
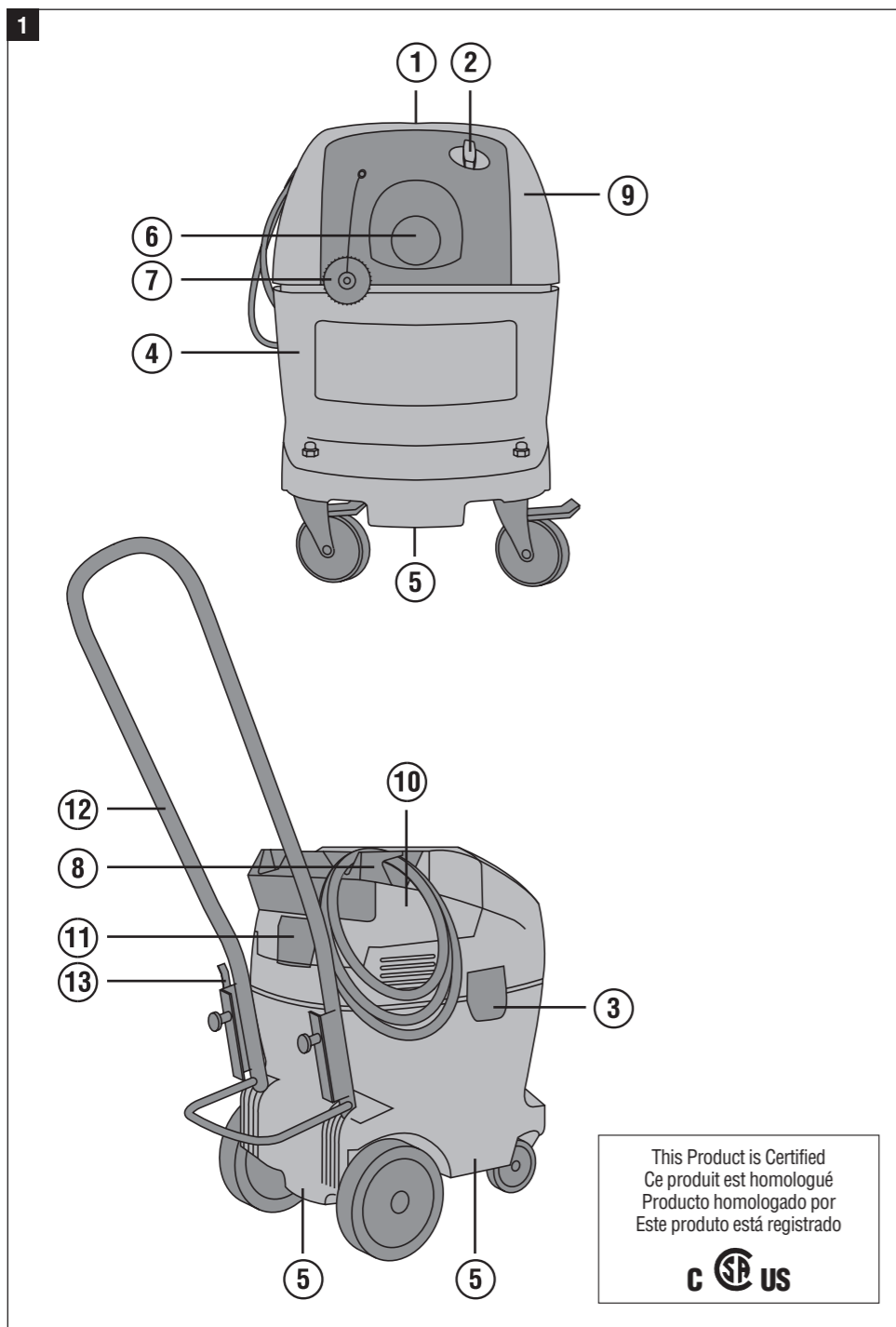

# VC 20-U/ VC 40-U Wet / dry vacuum cleaner

en

***It is essential that the operating instructions are read before the appliance is operated for the first time.***

***Always keep these operating instructions together with the appliance.***

***Ensure that the operating instructions are with the appliance when it is given to other persons.***

Contents	Page
1. General information	1
2. Description	2
3. Accessories	4
4. Technical data	4
5. Safety instructions	5
6. Before use	8
7. Operation	9
8. Care and maintenance	11
9. Troubleshooting	13
10. Disposal	14
11. Manufacturer's warranty	14

**1** These numbers refer to the corresponding illustrations. The illustrations can be found on the fold-out cover pages. Keep these pages open while studying the operating instructions.

In these operating instructions, the designation "the appliance" always refers to the VC 20/40 wet/dry vacuum cleaners.

## Parts, operating controls and indicators **1**

- ① Grip
- ② Control switch
- ③ Catch
- ④ Waste material container
- ⑤ Gripping areas
- ⑥ Hose socket
- ⑦ Cap for hose socket
- ⑧ Supply cord hooks
- ⑨ Vacuum cleaner top section
- ⑩ Filter cover
- ⑪ Locking clip for filter cover
- ⑫ Handlebar with cradle
- ⑬ Cradle catch

## 1. General information

### 1.1 Safety notices and their meaning

#### DANGER

Draws attention to imminent danger that could lead to serious bodily injury or fatality.

#### WARNING

Draws attention to a potentially dangerous situation that could lead to serious personal injury or fatality.

#### CAUTION

Draws attention to a potentially dangerous situation that could lead to slight personal injury or damage to the equipment or other property.

#### NOTE

Draws attention to an instruction or other useful information.

### 1.2 Explanation of the pictograms and other information

#### Prohibition signs



Transport by crane is not permissible.

#### Warning signs



General warning



Warning: caustic substances



Warning: electricity



Warning: explosive substances

en

### Obligation signs



Wear protective clothing



Wear eye protection.



Wear protective gloves.



Wear a hard hat.



Wear ear protection.



Wear safety shoes.



Wear respiratory protection!

### Symbols



Read the operating instructions before use.



Return waste material for recycling.

### Location of identification data on the appliance

The type designation and serial number can be found on the type identification plate on the appliance. Make a note of this data in your operating instructions and always refer to it when making an enquiry to your Hilti representative or service department.

Type: \_\_\_\_\_

Serial no.: \_\_\_\_\_

## 2. Description

### 2.1 Use of the product as directed

The VC 20/40 is a universal industrial vacuum cleaner with an effective filter cleaning system for dry dust. It is suitable for wet and dry vacuum cleaning applications.

The appliance is suitable for collecting the slurry created by wet drilling or wet cutting operations on mineral materials using Hilti diamond coring or Hilti diamond sawing equipment and for collecting large quantities of dry mineral dust when working with Hilti diamond grinders and cutters, rotary hammers and dry cutting core bits.

The appliance may also be used to pick up liquid waste material.

It is suitable for picking up drilling slurry from mineral materials.

Picking up oil or liquids with a temperature of over 60°C (140°F) is not permissible.

When picking up dusts with an exposure limit value, steps must be taken to ensure adequate air exchange in the room if the exhaust air from the appliance is released into the room (please observe the locally applicable regulations).

Do not use the appliance to pick up explosive substances or glowing, flammable, burning and aggressive dusts or liquids (e.g. magnesium or aluminium dust, gasoline, solvents, acids, coolants and lubricants, etc.).

Do not operate the appliance when laid on its side (always operate in upright position).

Fully loaded with the material picked up, the total weight of the VC 20 must not exceed 37 kg (81.57) lb.

Fully loaded with the material picked up, the total weight of the VC 40 must not exceed 55 kg (121.25) lb.

Do not stand on the appliance (do not use as a substitute for a ladder).

Do not use the appliance for continuous, stationary operation in automatic or semi-automatic systems.

The operating personnel must be instructed on how to use the appliance prior to beginning work, they must be informed of any hazards associated with the materials to be picked up and they must be familiar with the correct procedures for safe disposal of these materials.

Underwater use is not permissible.



Use of the appliance to clean down persons or animals is not permissible.  
 Use an antistatic suction hose in order to avoid electrostatic effects.  
 This appliance is suitable for commercial use, e.g. in hotels, schools, hospitals, factories, shops, offices and by rental companies.  
 Working on materials hazardous to the health (e.g. asbestos) is not permissible.  
 The working environment may be as follows: construction site, workshop, renovation, conversion or new construction.  
 Observe the information printed in the operating instructions concerning operation, care and maintenance.  
 To avoid the risk of injury, use only genuine Hilti tools and accessories.  
 The appliance and its ancillary equipment may present hazards when used incorrectly by untrained personnel or when used not as directed.  
 Modification of the appliance or tampering with its parts is not permissible.

en

**2.2 The items supplied as standard include:**

- 1 Appliance with filter element
- 1 Suction hose complete with hose connector, hose sleeve and tapered adapter
- 1 PE VC 20 plastic dust bag
- 1 Paper dust bag VC 40
- 1 Operating instructions

**2.3 Using extension cords**

Use only extension cords of a type approved for the application and with conductors of adequate gauge. The appliance may otherwise lose performance and the extension cord may overheat. Check the extension cord for damage at regular intervals. Replace damaged extension cords.

**Recommended minimum cross section and max. cord length for the VC 20/40:**

Conductor cross section	12 AWG	14 AWG	16 AWG
Mains voltage 110-120 V	150 ft	100 ft	50 ft

Use only extension cords equipped with an earth/ground conductor.

**2.4 Using extension cords outdoors**

When working outdoors, use only extension cords that are approved and correspondingly marked for this application.

**2.5 Using a generator or transformer**

This appliance may be powered by a generator or transformer when the following conditions are fulfilled: The unit must provide a power output in watts of at least twice the maximum value printed on the type identification plate on the power tool or appliance. The operating voltage must remain within +5% and -15% of the rated voltage at all times, frequency must be in the 50 – 60 Hz range and never above 65 Hz, and the unit must be equipped with automatic voltage regulation and starting boost.

Never operate other power tools or appliances from the generator or transformer at the same time. Switching other power tools or appliances on and off may cause undervoltage and / or overvoltage peaks, resulting in damage to the power tool or appliance.



## 2.6 Use of accessories

Accessories	Type of use
PE VC 20/40 plastic dust bag	Wet and dry
VC 20/ VC 40 paper dust bag	Wood dusts
VC 20/40 filter fleece	Dry
VC 20/40 filter element	Mainly dry
PES VC 20/40 filter element	Wet and dry
Suction hose, 27 X 3.5m AS	Specially for dry use
Suction hose, 36 mm dia., static type	Wet and dry
Suction hose, 36 x 5m AS	Specially for dry use
VC 20/40 HEPA filter element	Wet and dry

## 3. Accessories

Spare parts, tools and accessories are available through Hilti sales channels.

PE VC 20 plastic dust bag	203854
PE VC 40 plastic dust bag	203852
Paper dust bag VC 20	203858
Paper dust bag VC 40	203856
VC 20 filter fleece	203859
VC 40 filter fleece	203857
Filter element	203862
PES filter element	203863
HEPA filter element	203879
Suction hose, 27 mm dia., length 3.5 m	203865
Suction hose, 36 mm dia., static type	203866
Suction hose, 36 mm dia., length 5 m	203867
Accessory set	1 bend, 2 extension tubes, 1 floor nozzle with lamellar lips and 1 set of brushes, 203868
Hose connector	
Tapered adapter	203878
Handlebar (VC 40)	203870
Handlebar for DPC 20 (only VC 40)	203871

## 4. Technical data

Right of technical changes reserved.

Appliance	VC 20-U	VC 40-U
Rated voltage	120 V	120 V
Mains frequency	60 Hz	60 Hz
Weight	13.0 kg (28.66 lb)	14.6 kg (32.19 lb)

Appliance	VC 20-U	VC 40-U
Dimensions	505 mm (19.88 in) x 380 mm (14.96 in) x 500 mm (19.69 in)	505 mm (19.88 in) x 380 mm (14.96 in) x 610 mm (24.02 in)
Supply cord	7.5 m (24.61 ft)	7.5 m (24.61 ft)
Supply cord (type)	SJTW-A 3/16 AWG	SJTW-A 3/16 AWG
Max. suction performance (air)	61 l/s (16.12 gal/sec)	61 l/s (16.12 gal/sec)
Max. vacuum	Power 1,200 W: 23 kPa	Power 1,200 W: 23 kPa
Container capacity	21 l (5.55 gal)	36 l (9.51 gal)
Effective dust capacity	23 kg (50.71 lb)	40 kg (88.18 lb)
Effective water capacity	13.5 l (3.57 gal)	25 l (6.6 gal)
Suction hose diameter (rotary connector at nozzle end; connector at vacuum cleaner end)	Length 5 m (16.4 ft): 36 mm (1.42 in) Length 3.5 m (11.48 ft): 27 mm (1.06 in)	Length 5 m (16.4 ft): 36 mm (1.42 in) Length 3.5 m (11.48 ft): 27 mm (1.06 in)
Air temperature	-10...+40°C (+14...+104°F)	-10...+40°C (+14...+104°F)
Automatic filter cleaning approx. every	15 s	15 s

en

#### Information about the appliance and its applications

Protection class	Protection class I (earthed)
Protection class	IP X4 protection against sprayed water

## 5. Safety instructions

### 5.1 IMPORTANT SAFETY INSTRUCTIONS

**WARNING! READ ALL INSTRUCTIONS BEFORE USING THIS APPLIANCE!** Failure to follow all instructions listed below may result in electric shock, fire and/or serious injury. **SAVE THESE INSTRUCTIONS.**

- In addition to the information relevant to safety given in each of the sections of these operating instructions, the following points must be strictly observed at all times.
- Read all instructions! Failure to follow all instructions listed below may result in electric shock, fire and/or serious injury.
- Before use of the appliance together with a power tool, the operating instructions for the power tool must be read carefully and all safety instructions observed.

### 5.2 Requirements to be met by users

- Stay alert, watch what you are doing and use common sense when operating the appliance. Do not use the appliance while tired or under the influence of drugs, alcohol or medication. A

moment of inattention while operating appliances may result in serious personal injury.

- Dress properly. Do not wear loose clothing or jewellery. Keep your hair, clothing and gloves away from moving parts.** Loose clothes, jewellery or long hair can be caught in moving parts.
- Use safety equipment. Always wear eye protection.** Safety equipment such as dust mask, non-skid safety shoes, hard hat, or hearing protection used for appropriate conditions will reduce personal injuries.
- If devices are provided for the connection of dust extraction and collection facilities, ensure these are connected and properly used.** Use of these devices can reduce dust-related hazards.
- The machine is intended for professional use.**
- The machine may be operated, serviced and repaired only by authorized, trained personnel. This personnel must be informed of any special hazards that may be encountered.**
- Take special care when working on stairs.**
- Do not push anything into the openings on the appliance. Do not work with the appliance if the**

openings are blocked. Keep the openings free from dust, fluff, hair or anything else that could obstruct the flow of air.

en



### 5.3 Proper organization of the work area

- a) **Ensure that the workplace is well lit.**
- b) **Ensure that the workplace is well ventilated.**  
Exposure to dust at a poorly ventilated workplace may result in damage to the health.
- c) **Keep the work area tidy. Any objects which may cause injury should be removed from the area.**  
Untidiness at the workplace can lead to accidents.
- d) **Store appliances out of reach of children when not in use. Do not allow persons unfamiliar with the appliance or these instructions to operate it.**  
Appliances are dangerous in the hands of untrained users.
- e) **Keep children and other persons away from the area while the appliance is in use.** Distractions can cause you to lose control.
- f) **Do not operate appliances in explosive atmospheres, such as in the presence of flammable liquids, gases or dust.** Appliances create sparks which may ignite the dust or fumes.
- g) **Do not allow other persons to touch the appliance or the extension cord.**
- h) **Avoid unusual body positions. Make sure you work from a safe stance and stay in balance at all times.**
- i) **Wear non-skid shoes.**
- j) **Always lead the supply cord, the extension cord and the suction hose away to the rear when working.** This will help to prevent tripping while working.
- k) **After finishing the work, always tidy up and stow the supply cord, extension cord and suction hose away securely.** This will reduce the risk of tripping and falling.
- l) **Do not transport the appliance by crane.**
- m) **Check to ensure that the appliance is switched off before plugging the supply cord into a power outlet.**
- n) **WARNING: Some dust created by grinding, sanding, cutting and drilling contains chemicals known to cause cancer, birth defects, infertility or other reproductive harm; or serious and per-**

manent respiratory or other injury. Some examples of these chemicals are: lead from lead-based paints, crystalline silica from bricks, concrete and other masonry products and natural stone, arsenic and chromium from chemically-treated lumber. Your risk from these exposures varies, depending on how often you do this type of work. **To reduce exposure to these chemicals, the operator and bystanders should work in a well-ventilated area, work with approved safety equipment, such as respiratory protection appropriate for the type of dust generated, and designed to filter out microscopic particles and direct dust away from the face and body. Avoid prolonged contact with dust. Wear protective clothing and wash exposed areas with soap and water.** Allowing dust to get into your mouth, nose, eyes, or to remain on your skin may promote absorption of harmful chemicals.

### 5.4 General safety rules

- a) **Use the right appliance for the job. Do not use the appliance for purposes for which it was not intended. Use it only as directed and when in faultless condition.**
- b) **Never leave the appliance unattended.**
- c) **Take the influences of the surrounding area into account. Do not use the appliance where there is a risk of fire or explosion.**
- d) **Protect the appliance from frost.**
- e) **Store appliances in a secure place when not in use.** When not in use, appliances must be stored in a dry, high place or locked away out of reach of children.
- f) **Check to ensure that the cap is fitted to the hose socket during transport and when the vacuum cleaner is not in use.**
- g) **Always unplug the supply cord from the power outlet when the appliance is not in use (during breaks), before cleaning and maintenance and before changing the filter.**
- h) **Switch the appliance off before transporting it.**
- i) **Check the appliance and its accessories for any damage. Guards, safety devices and any slightly damaged parts must be checked carefully to ensure that they function faultlessly and as intended. Check that moving parts function correctly without sticking and that no parts are damaged. All parts must be fitted correctly and fulfill all conditions necessary for correct oper-**



ation of the appliance. Damaged guards, safety devices and other parts must be repaired or replaced properly at an authorized service center unless otherwise indicated in the operating instructions.

- j) Check that the filter is seated correctly. Check to ensure that the filter is undamaged.
- k) Have your appliance serviced by a qualified repair person using only identical replacement parts. This will ensure that the safety of the appliance is maintained.
- l) Disconnect the plug from the power source before making any adjustments, changing accessories, or storing the appliance. Such preventive safety measures reduce the risk of starting the appliance accidentally.
- m) Use the appliance and its accessories etc. in accordance with these instructions and in the manner intended for the particular type of appliance, taking into account the working conditions and the work to be performed. Use of appliances for applications different from those intended could result in a hazardous situation.
- n) Do not pull the wheels of the vacuum cleaner over the supply cord.
- o) The water level limiting device must be cleaned regularly in accordance with instructions and checked for signs of damage.

#### 5.5 Mechanical

- a) Follow the instructions concerning care and maintenance.
- b) Keep the appliance well maintained. Check for misalignment or binding of moving parts, breakage of parts and any other condition that may affect operation of the appliance. If damaged, have the appliance repaired before use. Many accidents are caused by poorly maintained appliances.

#### 5.6 Electrical



- a) The appliance's supply cord plug must match the outlet. Never modify the plug in any way. Do not use any adapter plugs with earthed (grounded) appliances. Unmodified plugs and matching outlets will reduce risk of electric shock.

b) Insert the plug in a suitable earthed/grounded power outlet which has been correctly and safely installed and is in compliance with local regulations.

- c) If you are in doubt about the effectiveness of the power outlet's earth/ground connection, have it checked by a qualified specialist.
- d) Avoid body contact with earthed or grounded surfaces such as pipes, radiators, ranges and refrigerators. There is an increased risk of electric shock if your body is earthed or grounded.
- e) Do not expose appliances to rain or wet conditions. Water entering an appliance will increase the risk of electric shock.
- f) Check the appliance's supply cord at regular intervals and have it replaced at a Hilti service center if damage is found. Check extension cords at regular intervals and replace them if found to be damaged.
- g) Check the condition of the appliance and its accessories. Do not operate the appliance and its accessories if damage is found, if the appliance is incomplete or if its controls cannot be operated faultlessly.
- h) Do not touch the supply cord or extension cord if they are damaged while working. Disconnect the supply cord plug from the power outlet. Damaged supply cords present a risk of electric shock.
- i) The electric supply cord may be replaced only with a cord of the type specified in the operating instructions.
- j) Damaged or faulty switches must be replaced at a Hilti service center. Do not use the appliance if it cannot be switched on and/or off correctly.
- k) Have the appliance repaired only by a trained electrical specialist (Hilti service center) using genuine Hilti spare parts. Failure to observe this point may result in risk of accident to the user.
- l) Do not abuse the cord. Never use the cord for carrying, pulling or unplugging the appliance. Keep the cord away from heat, oil, sharp edges or moving parts. Damaged or entangled cords increase the risk of electric shock.
- m) When operating an appliance outdoors, use an extension cord suitable for outdoor use. Use of a cord suitable for outdoor use reduces the risk of electric shock.
- n) In case of an interruption in the electric supply: Switch the appliance off and unplug the supply cord.

en

en

- o) Avoid using extension cords with multiple power outlets and the simultaneous use of several appliances connected to one extension cord.
- p) Never spray the top section of the vacuum cleaner with water: this presents an electrical hazard and may damage the appliance.
- q) Connectors on mains power cables, extension cords or supply cords must provide protection from sprayed water.
- r) Grip the plug when unplugging the supply cord (do not pull or tug at the supply cord).
- s) Never pull the vacuum cleaner by the supply cord to a new working position.
- t) Never operate the appliance when it is dirty or wet. Dust (especially dust from conductive materials) or dampness adhering to the surface of the appliance may, under unfavorable conditions, lead to electric shock. Dirty or dusty appliances should thus be checked at a Hilti service center at regular intervals, especially if used frequently for working on conductive materials.
- u) Check to ensure that the supply cord does not lie in a puddle of water.
- v) Do not use the power outlet or accessories when the hands are wet.

#### 5.7 Material picked up



- a) Do not use the appliance to pick up flammable or explosive dusts (magnesium or aluminium dust etc.) or dusts which present a health hazard.
- b) Do not use the appliance to pick up flammable, explosive or aggressive liquids (coolants and

- lubricants, gasoline, solvents, acids (pH<5), alkalis (pH>12.5) etc.)
- c) Switch the appliance off immediately if foam or liquids escape from it.
- d) Avoid contact with alkaline or acidic liquids. If contact accidentally occurs, flush with water. In the event of the liquid coming into contact with the eyes, rinse the eyes with plenty of water and consult a doctor.
- e) Wear protective gloves when using the vacuum cleaner to pick up hot materials with a max. temperature of 60°C.
- f) Do not pick up objects or materials that could cause injury by piercing through the dust bag (e.g. pointed or sharp objects).

#### 5.8 Thermal

Do not use the vacuum cleaner to pick up hot materials with a temperature of over 60°C (glowing cigarettes, hot ash, etc.).

#### 5.9 Personal protective equipment



- a) The user and any other persons in the vicinity must wear ANSI Z87.1 approved eye protection, a hard hat, ear protection, protective gloves, safety footwear and respiratory protection (P2) while the appliance is in use or during servicing.
- b) When working with mineral drilling slurry, wear protective clothing and avoid skin contact with the slurry (pH>9: caustic).

## 6. Before use



#### CAUTION

The mains voltage must comply with the specification given on the type identification plate. Ensure

that the appliance is disconnected from the electric supply.

#### DANGER

Connect the appliance only to properly earthed/grounded power sources.

### CAUTION

Always check to ensure that the vacuum cleaner is standing securely. Engage the castor brakes.

### CAUTION

When fitting the top section of the vacuum cleaner, take care to avoid pinching your fingers or damaging the supply cord.

#### 6.1 Use of extension cords and generators or transformers

See section "Description / use of extension cords".

#### 6.2 Operating the appliance for the first time 2

1. Open the two catches.
2. Lift the vacuum cleaner top section away from the waste material container.
3. Remove the accessories and packaging from the waste material container.
4. Fit a plastic dust bag in the container in accordance with the instructions (see printed instructions).
5. Fit the vacuum cleaner top section onto the waste material container.
6. Close the two catches.
7. Check to ensure that the vacuum cleaner top section is fitted correctly and secured.
8. Connect the suction hose to the appliance.

#### 6.2.1 Fitting a paper dust bag for picking up wood dust 3

1. Open the two catches.
2. Lift the vacuum cleaner top section away from the waste material container.
3. Place the new paper dust bag in the waste material container.
4. Fit the vacuum cleaner top section onto the waste material container.

5. Close the two catches.
6. Check to ensure that the vacuum cleaner top section is fitted correctly and secured.
7. Connect the suction hose to the appliance.

#### 6.3 Power conditioner

en

### CAUTION

When placing the power conditioner in the cradle check that the power outlet faces upwards and the spring catch engages.

### CAUTION

To avoid injury, remove the power conditioner and any loose accessories from their attachment points before emptying the container and before transporting the vacuum cleaner.

#### 6.4 Transport

### DANGER

Check to ensure that the cap is fitted to the hose socket during transport and when the vacuum cleaner is not in use.



### DANGER

The appliance may be moved or transported only when the motor has come to a complete stop.

Do not carry the appliance when it is full of waste material.

Empty the appliance before carrying it to another location.

Do not tip the appliance or lay it on its side for transport after using it to collect water.

The tapered adapter can be used to connect both ends of the hose together for transport.

## 7. Operation

### CAUTION

Always check to ensure that the vacuum cleaner is standing securely. Engage the castor brakes.

#### 7.1 Operation

### NOTE

Check that the appliance is switched off before plugging it into the power outlet (control switch in the "OFF" position).

1. Plug the supply cord into the power outlet.
2. Turn the control switch to the "ON" position.

### 7.2 Picking up dry dust

en

#### NOTE

Before using the appliance to pick up dry dust, especially dust from mineral materials, always check to ensure that the correct dust bag (Hilti accessory) is fitted in the container. The material collected can then be disposed of cleanly and easily.

#### CAUTION

**The material collected must be disposed of in accordance with the applicable regulations.**

#### CAUTION

**Never use the appliance without a filter element.**

#### CAUTION

**When fitting the top section of the vacuum cleaner, take care to avoid pinching your fingers or damaging the supply cord.**

Check to ensure that the filter element is dry. A damp filter element will quickly become clogged when dry dust is picked up with the appliance. Accordingly, before being used for picking up dry dust, the filter element should be rinsed and allowed to dry or replaced with another dry filter element.

### 7.2.1 Changing the paper dust bag / filter fleece

#### DANGER

**Check that the bag has not been pierced through by objects which may cause injury.**

#### CAUTION

**The material collected must be disposed of in accordance with the applicable regulations.**

1. Disconnect the supply cord plug from the power outlet.
2. Open the two catches.
3. Lift the vacuum cleaner top section away from the waste material container.
4. Carefully remove the paper dust bag collar from the adapter and remove the filter fleece.
5. Close the slider at the dust bag collar (place the cover over the filter fleece).
6. Clean the waste material container.
7. Fit a new dust bag / filter fleece in the waste material container.
8. Fit the vacuum cleaner top section onto the waste material container.

9. Close the two catches.

### 7.2.2 Changing the plastic dust bag 4

#### CAUTION

**The material collected must be disposed of in accordance with the applicable regulations.**

1. Disconnect the supply cord plug from the power outlet.
2. Open the two catches.
3. Lift the vacuum cleaner top section away from the waste material container.
4. Use a cable tie to close the plastic dust bag below the punched holes.
5. Remove the plastic dust bag.
6. Clean the waste material container.
7. Fit a new plastic dust bag (see instructions printed on it) in the waste material container.
8. Fit the vacuum cleaner top section onto the waste material container.
9. Close the two catches.

### 7.3 Picking up liquids

#### CAUTION

**Never use the appliance without a filter element.**

#### 7.3.1 Before picking up liquids

1. Remove the dust bag from the waste material container.
2. Check to ensure that the electrodes of the level monitoring system are clean. Clean them with a brush if necessary.

#### 7.3.2 When picking up liquids

If possible, use a separate filter element for wet applications.

#### NOTE

If possible, use a Hilti PES filter element.

If foaming occurs, switch the appliance off immediately and empty the container.

The appliance switches itself off automatically when the liquid in the container reaches the maximum level.

#### 7.3.3 After picking up liquids 5

1. Open the two catches.
2. Lift the vacuum cleaner top section away from the waste material container.
3. Empty the waste material container. Clean the container, the electrodes and the filter element.

4. Leave the vacuum cleaner top section and the container standing separately so that the container can dry.

#### 7.4 After finishing work

1. Turn the control switch to the "OFF" position.
2. Disconnect the supply cord plug from the power outlet.
3. Coil up the supply cord and hang it on the hook.
4. Empty the container and clean the appliance.
5. Coil up the suction hose.
6. Store the appliance in a secure, dry place where it is inaccessible to unauthorized users.

#### 7.5 Emptying the waste material container

##### CAUTION

To avoid injury, remove the power conditioner and any loose accessories from their attachment points before emptying the container and before transporting the vacuum cleaner.

##### 7.5.1 Emptying dry dust from the waste material container

###### 7.5.1.1 Before emptying the waste material container, proceed as follows:

1. Disconnect the supply cord plug from the power outlet.

2. Lift the vacuum cleaner top section away from the waste material container and place it on a level surface.

###### 7.5.1.2 After emptying the waste material container, proceed as follows:

##### CAUTION

When fitting the top section of the vacuum cleaner, take care to avoid pinching your fingers or damaging the supply cord.

Fit the vacuum cleaner top section onto the waste material container and close the two catches.

###### 7.5.2 Emptying the waste material container when no dust bag is fitted (collecting liquids)

##### NOTE

The material collected must be disposed of in accordance with the applicable regulations.

1. Hold the container by the grip areas provided and tip it over to empty out its contents.
2. Clean the edge of the waste material container.

en

## 8. Care and maintenance

#### 8.1 Automatic filter element cleaning

##### NOTE

Do not attempt to clean the filter element by knocking it against a hard object and do not use pointed instruments. This will reduce the life of the filter element.

##### NOTE

Do not use compressed air to clean the filter element. This may cause tears in the filter material.

##### NOTE

The condition of the filter will deteriorate with use. It should be replaced at least every 6 months and more frequently if the appliance is subject to heavy use.

The appliance is equipped with a filter cleaning system which removes most of the dust adhering to the filter element.

The filter element is cleaned automatically by a blast of air (a pulsating noise is heard).

##### NOTE

The filter element cleaning system functions only when a suction hose is connected.

#### 8.2 Changing the filter element

##### CAUTION

Never use the appliance without a filter element.

##### 8.2.1 Removing the filter element

1. Disconnect the supply cord plug from the power outlet.
2. Open the filter cover catches.
3. Open the filter cover.
4. Carefully remove the filter element, gripping it at the areas provided in the holder.

### 8.2.2 Fitting the filter element

1. Clean the filter sealing surfaces.
2. Fit the new filter element.
3. Close the filter cover by pivoting the cover catch forward.
4. Close the filter cover catches.

### 8.3 Opening the appliance for checking

1. Engage the castor brakes.
2. Disconnect the supply cord plug from the power outlet.
3. Open the two catches.
4. Lift the vacuum cleaner top section away from the waste material container and place it on a level surface.

### 8.4 Checking the waste material level

Check that the cut-out contacts are free from dirt and dust and clean them if necessary.

### 8.5 Closing the appliance

#### CAUTION

When fitting the top section of the vacuum cleaner, take care to avoid pinching your fingers or damaging the supply cord.

1. Fit the vacuum cleaner top section onto the waste material container.
2. Close the two catches.

### 8.6 Care of the appliance

#### CAUTION

Disconnect the supply cord plug from the power outlet.

Never operate the appliance when the ventilation slots are blocked. Clean the ventilation slots carefully using a dry brush. Clean the outside of the appliance at regular intervals with a cloth. Do not use a spray, high-pressure water-jet system, steam pressure cleaning

equipment or running water for cleaning. This may negatively affect the electrical safety of the appliance. Always keep the grip surfaces of the appliance free from oil and grease. Do not use cleaning agents which contain silicone.

The appliance must be handled for cleaning and maintenance in a way that avoids exposing maintenance personnel and other persons to any hazards. Use filtered forced ventilation. Wear personal protective equipment. Clean the maintenance area in a way that prevents hazardous substances escaping into the surrounding environment.

Vacuum off the outer surfaces of the appliance, wipe it clean or seal it in suitable container or material before removing it from an area contaminated with hazardous substances. This will help to avoid distribution of the hazardous dust deposited on it.

When maintenance or repairs are carried out, all contaminated parts which cannot be satisfactorily cleaned must be packed in impermeable bags and disposed of in compliance with the applicable disposal regulations.

### 8.7 Maintenance

#### WARNING

Repairs to the electrical section of the appliance may be carried out only by trained electrical specialists.

Check all external parts of the appliance for damage at regular intervals and check that all controls operate faultlessly. Do not operate the appliance if parts are damaged or when the controls do not function faultlessly. If necessary, the appliance should be repaired by Hilti Service.

### 8.8 Checking the appliance after care and maintenance

After carrying out cleaning and maintenance, check that the vacuum cleaner has been correctly reassembled and that it operates faultlessly.

Test each of the functions.

## 9. Troubleshooting

Fault	Possible cause	Remedy
No suction / reduced suction performance.	The dust bag is full.	Change the dust bag. See section: 7.2.2 Changing the plastic dust bag  See section: 7.2.1 Changing the paper dust bag / filter fleece
	The filter element is clogged with dirt or dust.	Change the filter element if necessary. See section: 8.2 Changing the filter element
	Blockage in the hose, vacuum cleaner or power tool dust hood.	Clean the hose and dust hood.
Dust is blown out of the appliance.	The filter element is not fitted correctly.	Remove the filter element and refit it correctly.
	The filter element is damaged.	Fit a new filter element.
	The filter seal is damaged.	Fit a new filter element.
The appliance switches itself off or on inadvertently or the user receives electric shocks (static discharge).	Electrostatic charge is not dissipated correctly; the appliance is connected to an unearthed/ungrounded power outlet.	Connect the appliance to an earthed/grounded power outlet; use an antistatic hose.
The appliance doesn't start or switches itself off after a short time.	The water level cut-out is activated.	Clean the sensors and the area around the sensors.
The motor doesn't restart.	The mains circuit breaker has been tripped.	Reset the circuit breaker. Find the reason for the overload current if it trips again.
	The container is full.	Switch the appliance off. Empty the container. See section: 7.5.2 Emptying the waste material container when no dust bag is fitted (collecting liquids)
	The motor overheating protection cut-out has been activated.	Switch off the appliance and allow it to cool for 5 min. If the motor still doesn't start, contact Hilti Service.
	The motor overheating protection cut-out switches the motor off repeatedly as the ventilation slots are clogged.	Clean the ventilation slots carefully with a dry brush.
The automatic filter element cleaning system doesn't work.	No suction hose is connected.	Connect the suction hose.

en

## 10. Disposal



en

Most of the materials from which Hilti power tools or appliances are manufactured can be recycled. The materials must be correctly separated before they can be recycled. In many countries, Hilti has already made arrangements for taking back your old power tools or appliances for recycling. Ask Hilti customer service or your Hilti representative for further information.

Disposing of drilling slurry directly into rivers, lakes or the sewerage system without suitable pretreatment presents environmental problems. Ask the local public authorities for information about current regulations. We recommend the following pretreatment:

1. Collect the drilling slurry (for example, using a wet-type vacuum cleaner).
2. Allow the drilling slurry to settle and dispose of the solid material at a construction waste disposal site (the addition of a flocculent may accelerate the separation process).
3. The remaining water (alkaline, pH value greater than 7) must be neutralized by the addition of an acidic neutralizing agent or diluted with a large volume of water before it is allowed to flow into the sewerage system.

The drilling dust collected must be disposed of in accordance with the applicable national regulations.

## 11. Manufacturer's warranty

Hilti warrants that the tool supplied is free of defects in material and workmanship. This warranty is valid so long as the tool is operated and handled correctly, cleaned and serviced properly and in accordance with the Hilti Operating Instructions, and the technical system is maintained. This means that only original Hilti consumables, components and spare parts may be used in the tool.

This warranty provides the free-of-charge repair or replacement of defective parts only over the entire lifespan of the tool. Parts requiring repair or replacement as a result of normal wear and tear are not covered by this warranty.

**Additional claims are excluded, unless stringent national rules prohibit such exclusion. In particular, Hilti is not obligated for direct, indirect, incidental or consequential damages, losses or expenses in connection with, or by reason of, the use of, or inability to use the tool for any purpose. Implied warranties of merchantability or fitness for a particular purpose are specifically excluded.**

For repair or replacement, send the tool or related parts immediately upon discovery of the defect to the address of the local Hilti marketing organization provided.

This constitutes Hilti's entire obligation with regard to warranty and supersedes all prior or contemporaneous comments and oral or written agreements concerning warranties.