

# **POWERNAIL® CO.**

1300 Rose Road, Lake Zurich, IL 60047

Phone: 1-800-323-1653

Website: <http://www.powernail.com>

## *Operation and Maintenance Manual*

### **Models 20FS Pneumatic PowerStapler™**

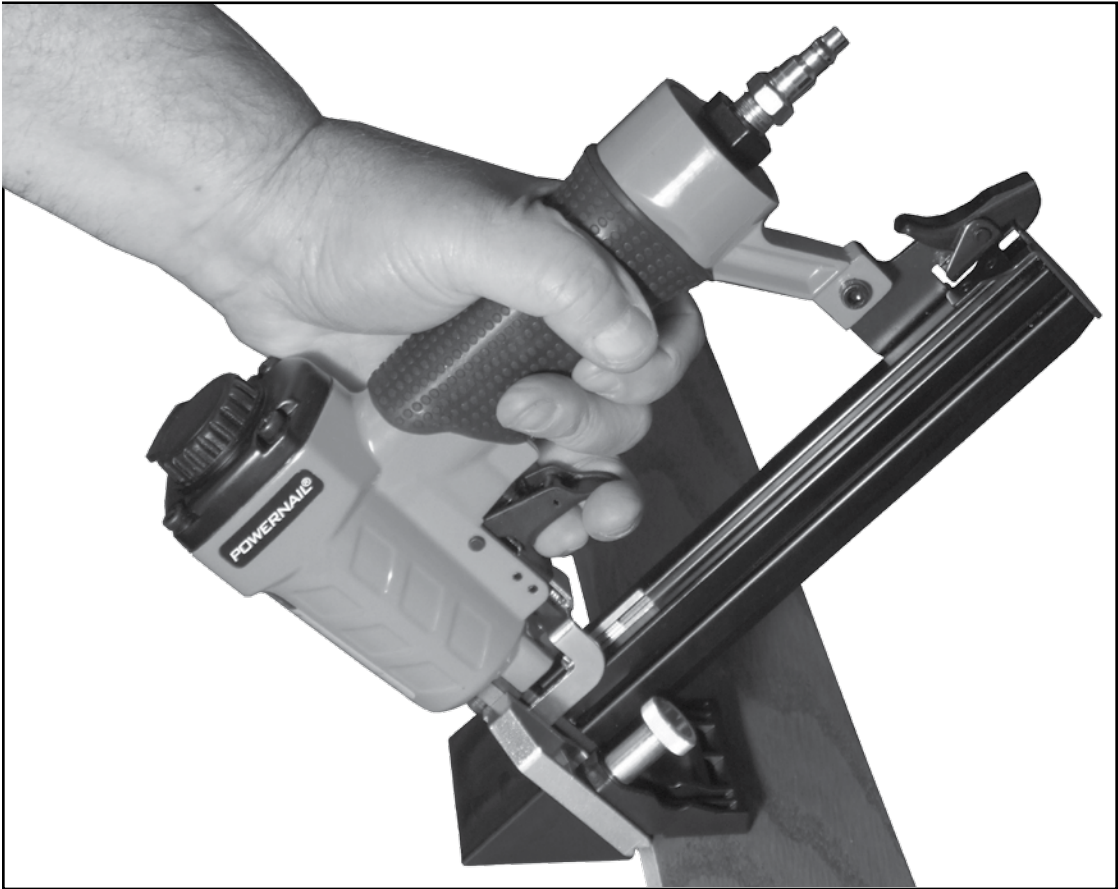

#### **WARNING**

Read this manual before you use this Stapler. Follow all safety warnings and instructions. Do not attempt any disassembly or repairs while the air line is connected. Always disconnect the air line first. Do not use excessive unregulated air pressure.

If you are uncertain about the operation of the Stapler, call us directly a 1-800-323-1653 for assistance or contact the closest Powernail® Dealer for help. Please retain this information for future reference.

REV 10.07.01

## DESCRIPTION

The PowerStapler® Model 20FS trigger pull stapler is the latest model designed to bring Powernail quality and flooring expertise to a pneumatic Stapler.

The PowerStapler Model 20FS is designed for use with 1", 20 gauge PowerStaples®.

The Model 20FS can staple down from 3/8" to 1/2" flooring through the use of an easy-to-adjust foot that can be adjusted to fit different flooring profiles.

To use the Model 20FS, simply snug up the flooring, pull the safety trigger and let the Stapler drive and set the staple at the correct 45 degree angle.

For a superior pneumatic Stapler, look to the company that has been the industry's quality leader for over 60 years, Powernail® Company, Inc.

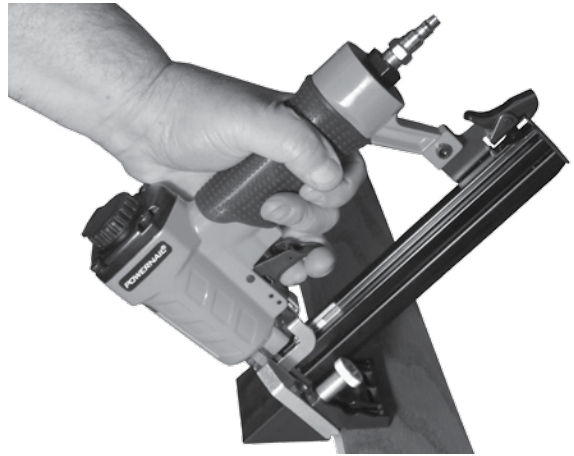

## SAFETY PRECAUTIONS TO PREVENT ACCIDENTAL INJURIES:

**Read these instructions carefully before you use the Stapler.**

When operating this Stapler -including loading, unloading, operating or servicing this tool -always wear approved **EYE PROTECTION** safety glasses which have both front and side protection. Others in the work area should also wear front and side **EYE PROTECTION**. Eye protection will help guard against flying staples and debris, which could cause severe eye injury.

**EAR PROTECTION** may be required to prevent hearing damage when there are high noise levels in the work area.

Always **DISCONNECT THE AIR SUPPLY** before making any adjustments, repairing, clearing jams or when the Stapler is not in use.

Only use an unrestricted male connector directly attached to the Stapler. Never use a female quick disconnect plug directly on the Stapler. This can trap air inside the Stapler and permit it to be discharged.

Use only regulated compressed air, do not use bottled gases of any kind to power this Stapler. Normal air pressure should not exceed 100 psi or damage to the Stapler and seals may occur. Excess air pressure can cause the Stapler to explode.

Never place any part of the body in the discharge path of the Stapler when air is connected to the Stapler. Always make sure Stapler is empty of staples before connecting air hose so as to prevent any accidental discharge from occurring.

Never leave the Stapler unattended while it is connected to an air supply.

**DO NOT FIRE INTO HARD MATERIALS.** Do not attempt to use on hard or brittle material such as concrete, steel or tile.

### **Safety First!**

Always wear eye and ear protection



**CHECK DAMAGED PARTS.** Before using this tool, carefully check that all parts are working correctly. Do not use the tool if it is not operating correctly-**check for causes and adjust as necessary for proper operation.**

**STORE THE TOOL** in a dry location to reduce rust. When not in use, tool should be cleaned, fully assembled and then, stored in a dry place. For safety, keep out of reach of children.

**NEVER POINT THE TOOL** at yourself or others even if the tool is not loaded.

**TO PREVENT ACCIDENTAL FIRING** when you connect the air hose, remove all the fasteners before connecting the air hose.

**DO NOT DEPRESS THE TRIGGER WHEN LOADING.**

**IF THE FASTENERS ARE JAMMED,** disconnect the tool from the air before you remove the jammed staples.

# OPERATING INSTRUCTIONS

Figure 1.

## FOOT ADJUSTMENT / STAPLE LOCATION

Loosen both adjusting knobs (76)

Hold stapler on sample piece of sample flooring to be installed.

Adjust the face pad (74) so it lays flat on the finished surface of the flooring (Fig 1).

Lightly snug both adjusting knobs (76).

Push down on front stand (73) so it lays flat on the sub floor.

Tighten both adjusting knobs (76).

Test the adjustment by stapling down a sample piece of floor

Readjust if necessary so that the staple insertion point enters the top of the flooring nail pocket.

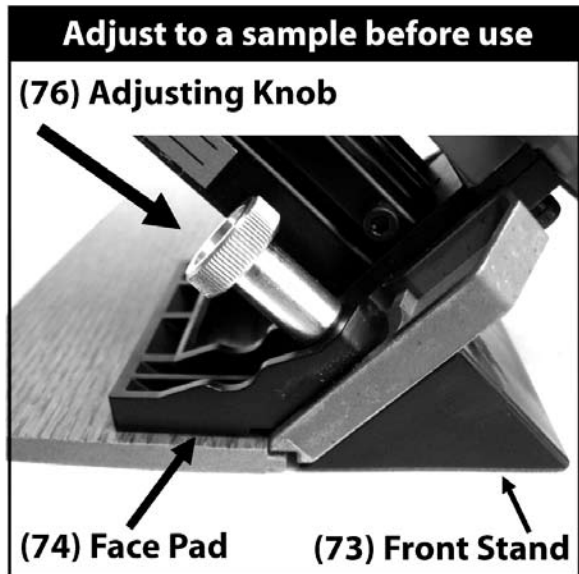

## SETTING

Your air tool is fully assembled when you receive it. Before using it, attach the air line and desired air system accessories. Be sure the air hose is depressurized when installing or removing adapters to the air line. To prevent misfire, do not connect air to a loaded nailer.

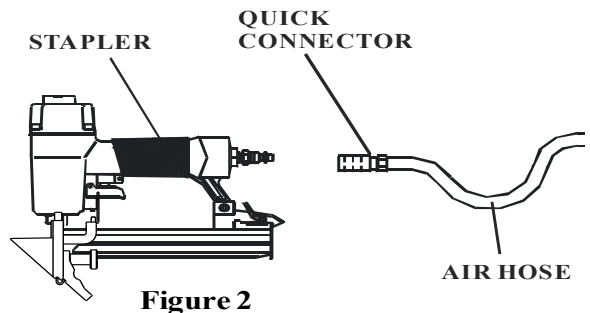

## CONNECTING THE TOOL TO AN AIR SUPPLY

1. Determine if the tool needs oil. An automatic airline oiler is recommended but oil may be added manually before every operation or after about 1 hour of continuous use.

2. Place two (2) drops of air-tool oil in the air plug as shown in Figure 3. If you are using an automatic in-line oiler, check and add oil if necessary.

3. Turn your compressor on and set the compressors pressure regulator to the proper pressure for the size and type of fastener being used. Normal operating pressure should be adjusted between 60-100 psi based on fastener and wood being used.

4. Connect the tool to the air supply (figure 2).

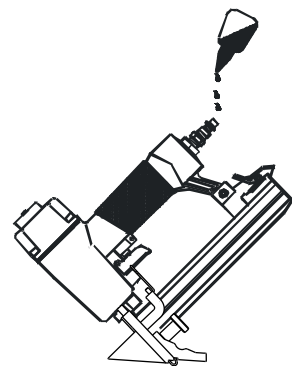

## OPERATION (continued)

### LOADING THE FASTENERS

1. Depress the LOCK(60) to release the MOVABLE

MAGAZINE (44) and pull the magazine out fully as shown in Figure 3.

2. Place a full clip of the specified type and size fasteners on the FIXED MAGAZINE (51), up to 125 fasteners may be loaded in the magazine.

3. Push the MOVABLE MAGAZINE ASSEMBLY forward until it is locked.

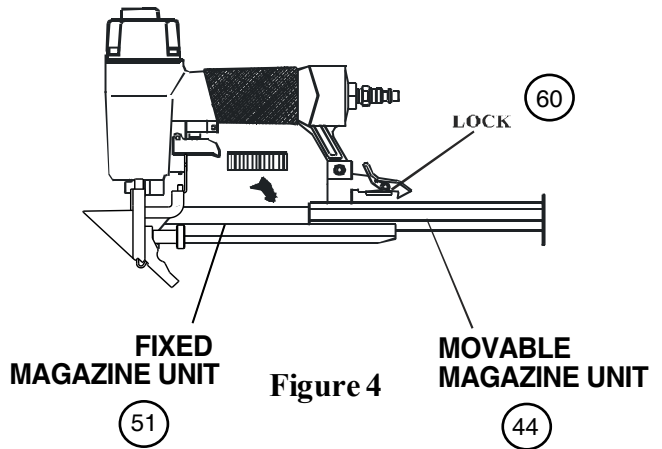

Figure 4

### REGULAR MAINTENANCE

## REGULAR MAINTENANCE

1. Frequent, but not excessive, lubrication is required for best performance. Oil added through the airline connection will lubricate internal parts. An automatic airline oiler is recommended but oil may be added manually before every operation or after about 1 hour of continuous use.

Only a few drops of oil at a time are necessary. Too much oil will collect inside the tool and be blown out during the exhaust cycle. **ONLY USE PNEUMATIC TOOL OIL.** Do not use detergent oil or additives, as these lubricants will cause accelerated wear to the seal in the tool.

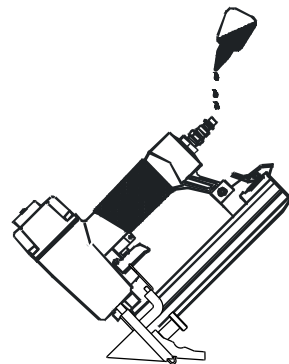

**Figure 3**

2. Use a small amount of oil on all moving surface and pivots.

3. Dirt and water in the air supply are major causes of pneumatic tool wear. Use a filter/oiler for better performance and longer life. The filter must have adequate flow capacity for the specific application. Consult the manufacturer's instructions for proper maintenance of your filter.

4. Keep tools clean for better and safer performance. Use nonflammable cleaning solutions (CAUTION: Such solutions may damage O-ring and other tool parts) only if necessary- DO NOT SOAK.

# Model 20FS SCHEMATIC

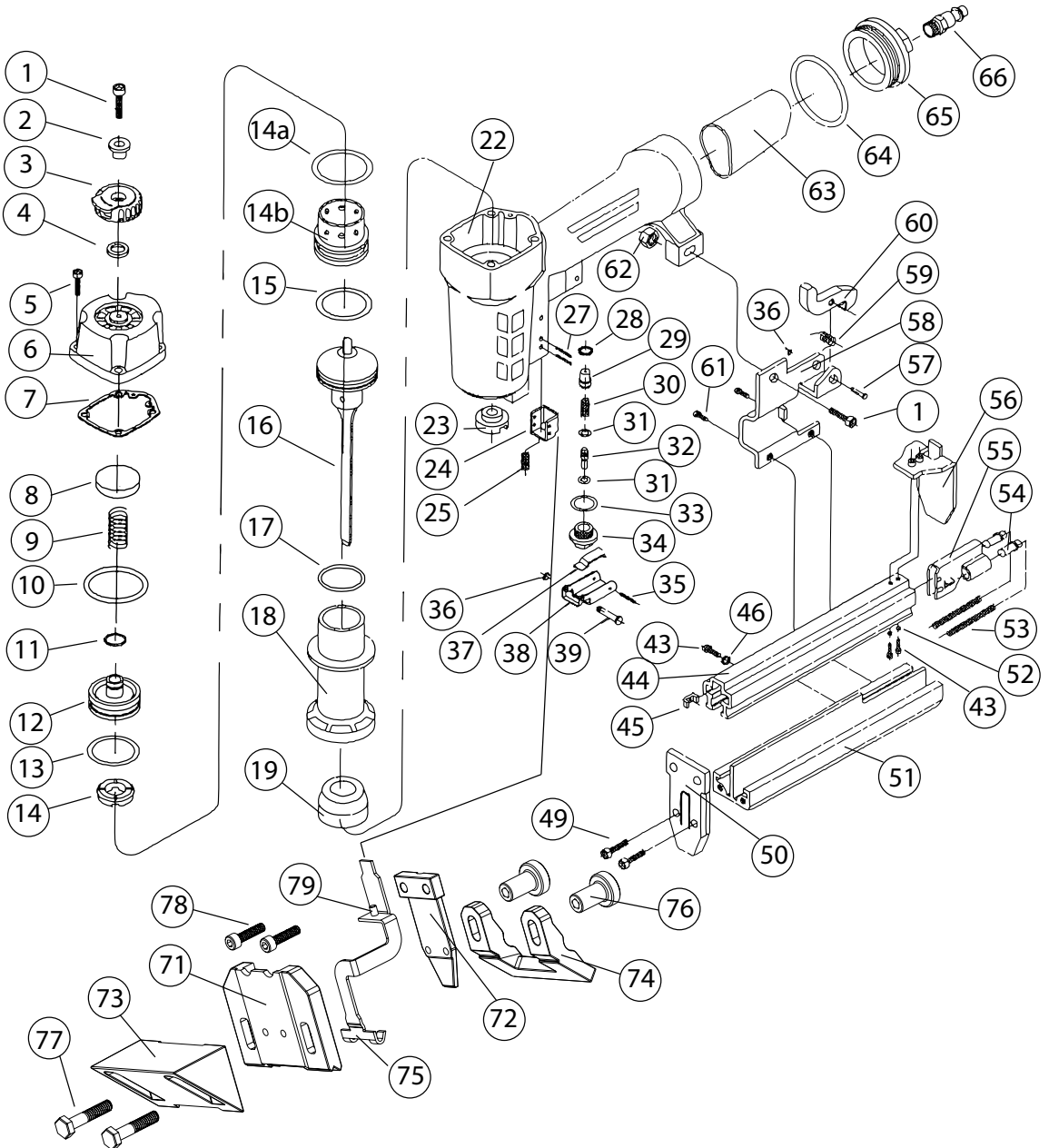

## PARTS LIST

ITEM	DESCRIPTION	PART #
1	Screw	n/a
2	Bushing	n/a
3	Exhaust Cover	n/a
4	Seal	n/a
5	Screw	n/a
6	Cylinder Cap	n/a
7	Gasket	n/a
8	Seal	n/a
9	Spring	n/a
10	O-Ring 36.3x2.5	n/a
11	O-Ring 15.7x2	n/a
12	Valve	n/a
13	O-Ring 33.5x3.5	n/a
14	Stopped Washer	n/a
14a	O-Ring 48.5x2.5	n/a
14b	Collar	n/a
15	O-Ring 48.5x2.5	n/a
16	Piston Assembly	n/a
17	O-Ring (27.3x2)	n/a
18	Cylinder	n/a
19	Bumper	n/a
22	Body	n/a
23	Joint Guider	n/a
24	Safe Bracket Guider	n/a
25	Spring	n/a
27	Pin	n/a
28	Seal	n/a
29	Trigger Valve Head	n/a
30	Spring	n/a
31	O-Ring (5.5x1.5)	n/a
32	Trigger Valve Stem	n/a
33	O-Ring (15x1.9)	n/a
34	Trigger Valve Guider	n/a
35	Pin	n/a
36	Locking Washer	n/a
37	Spring	n/a
38	Trigger	n/a
39	Pin	n/a
43	Screw	n/a
44	Movable Magazine Unit	n/a
45	Stopped Block	n/a

ITEM	DESCRIPTION	PART #
46	Spring Washer	n/a
49	Screw	n/a
50	Clap Plate	n/a
51	Fixed Magazine Unit	n/a
52	Washer	n/a
53	Spring	n/a
54	Feeder Shoe Retainer	n/a
55	Feeder Shoe	n/a
56	Stopped Plate	n/a
57	Pin	n/a
58	Support	n/a
59	Torsion Spring	n/a
60	Lock	n/a
61	Screw	n/a
62	Nut	n/a
63	Softgrip Sleeve	n/a
64	O-Ring (40.2x2.3)	n/a
65	End Cap	n/a
66	Air Plug	n/a
70	Maunal/Instructions	09-20FS-INST
71	Stapler Foot	09-20FS-5071
72	Stapler Gate Plate	09-20FS-5072
73	Stapler Support Shoe	09-20FS-5073
74	Stapler Foot Rest	09-20FS-5074
75	Stapler Safety	09-20FS-5075
76	Knob-Foot Rest	09-20FS-5076
77	1/4-28 x 1-1/4 Cap Screw	09-20FS-5077
78	M4-0.7 x 25mm SHCS	09-20FS-5078
79	.156 Dia Spring Pin	09-20FS-5079

## TROUBLE SHOOTING CHART

Here are some common issues may occur during use.

If the stapler is not working as it should be, stop using the tool immediately and resolve the issue before continuing.

	PROBLEM	POSSIBLE CAUSE	SOLUTION
1	Air leaking at Trigger area	1. O-ring in trigger valve is damaged.	1. Check and replace O-ring.
		2. Trigger valve head is damaged.	2. Check and replace trigger valve head.
		3. Trigger valve stem, seal or O-ring is damaged	3. Check and replace trigger valve stem, seal or O-ring.
2	Air leaking between body and drive guider	1. Damaged bumper	1. Check and replace bumper
3	Air leaking between body & cylinder cap	1. Screw loose.	1. Tighten screws.
		2. Damaged gasket.	2. Check and replace gasket.
4	Blade driving fastener too deeply	1. Worn bumper	1. Replace bumper
		2. Air pressure is too high.	2. Adjust the air pressure.
5	Runs slowly or has power loss	1. Insufficient oil.	1. Lubricate as instructed.
		2. Insufficient air supply.	2. Check air supply
		3. Broken spring in cylinder cap.	3. Replace spring
		4. Exhaust port is cylinder cap is blocked.	4. Replace damaged internal parts.
6	Tool skips a fastener	1. Worn bumper or damaged spring (53)	1 Replace bumper or pusher spring.
		2. Dirt in drive guider	2. Clean drive channel of front plate.
		3. Inadequate airflow to tool	3. Check hose and compressor fitting.
		4 Worn or dry O-ring on piston	4. Replace O-ring or lubricate.
		5. Cylinder cap seal leaking	5. Replace seal.
7	Fasteners are jammed	1. Joint guider is worn	1. Replace joint guider.
		2. Fasteners are wrong size or damaged.	2. Use the recommended and undamaged fasteners.
		3. Magazine or front plate screws are loose.	3. Tighten screws.
		4. Blade in piston assembly is damaged.	4. Replace piston assembly.
8	Tool will not drive down tight	1. Worn blade in piston assembly.	1. Replace piston assembly.
		2. Lack of power.	2. Adjust to adequate air pressure.
		3. Slow cycling and loss of power.	3. Check cylinder cap spring for broked coils or reduced length. Check if exhaust port of cylinder cap is restricted.