

Operator's Manual

Vibroplate

VP 1340

VP1340W

VP 1340W-L

VP 1340W-LL

VP1550

VP1550W



5000191727 04 0811



5 0 0 0 1 9 1 7 2 7

Copyright notice

© Copyright 2011 by Wacker Neuson Corporation.

All rights, including copying and distribution rights, are reserved.

This publication may be photocopied by the original purchaser of the machine. Any other type of reproduction is prohibited without express written permission from Wacker Neuson Corporation.

Any type of reproduction or distribution not authorized by Wacker Neuson Corporation represents an infringement of valid copyrights. Violators will be prosecuted.

Trademarks

All trademarks referenced in this manual are the property of their respective owners.

Manufacturer

Wacker Neuson Manila Incorporated

Lot 2, Blk 1 Phase 3, PEZA Drive, First Cavite Industrial Estate, Brgy. Langkaan
Dasmariñas, Cavite, Philippines

Tel: +63-(0)2-580-7136 Fax: +63-(0)2-580-7122

www.wackerneuson.com

Translated instructions

This Operator's Manual presents a translation of the original instructions. The original language of this Operator's Manual is American English.

Foreword	3
1. Emission System Control Information	4
2. Safety Information	9
2.1 Laws Pertaining to Spark Arresters	9
2.2 Operating Safety	10
2.3 Operator Safety while using Internal Combustion Engines	11
2.4 Service Safety	12
2.5 Label Locations	13
2.6 Warning and Informational Labels	14
3. Technical Data	17
3.1 Engine Data	17
3.2 Machine Data	18
3.3 Sound and Vibration Measurements	18
3.4 Dimensions	19
4. Operation	20
4.1 Recommended Fuel	20
4.2 Application	20
4.3 Before Starting	21
4.4 To Start	22
4.5 To Stop	22
4.6 Operation	23

5. Maintenance	24
5.1 Maintaining the Emission Control System.....	24
5.2 Periodic Maintenance Schedule	25
5.3 Spark Plug	26
5.4 Air Cleaner	27
5.5 Engine Oil	28
5.6 Adjusting Engine Speed	28
5.7 Cleaning Fuel Strainer	29
5.8 Drive Belt	30
5.9 Exciter Lubrication	31
5.10 Cleaning Plate	31
5.11 Lifting Machine	32
5.12 Transporting Machine	33
5.13 Storage	33
5.14 Troubleshooting	34

CALIFORNIA

Proposition 65 Warning:



Engine exhaust, some of its constituents, and certain vehicle components, contain or emit chemicals known to the State of California to cause cancer and birth defects or other reproductive harm.

Foreword

This manual provides information and procedures to safely operate and maintain this Wacker Neuson model. For your own safety and protection from injury, carefully read, understand and observe the safety instructions described in this manual.

Keep this manual or a copy of it with the machine. If you lose this manual or need an additional copy, please contact Wacker Neuson Corporation. This machine is built with user safety in mind; however, it can present hazards if improperly operated and serviced. Follow operating instructions carefully! If you have questions about operating or servicing this equipment, please contact Wacker Neuson Corporation.

The information contained in this manual was based on machines in production at the time of publication. Wacker Neuson Corporation reserves the right to change any portion of this information without notice.

All rights, especially copying and distribution rights, are reserved.

Copyright 2011 by Wacker Neuson Corporation.

No part of this publication may be reproduced in any form or by any means, electronic or mechanical, including photocopying, without express written permission from Wacker Neuson Corporation.

Any type of reproduction or distribution not authorized by Wacker Neuson Corporation represents an infringement of valid copyrights and will be prosecuted. We expressly reserve the right to make technical modifications, even without due notice, which aim at improving our machines or their safety standards.

Emission Control Systems Information and Warranty

1 Emission Control Systems Information and Warranty

The Emission Control Warranty and associated information is valid only for the U.S.A., its territories, and Canada.

1.1 Emission Control System Background Information

Introduction

Wacker Neuson spark-ignited engines/equipment must conform with applicable Environmental Protection Agency (EPA) and the State of California emissions regulations. There are two types of emissions that fall under these regulations: 1) exhaust, and 2) evaporative. These regulations require that manufacturers warrant the emission control systems for defects in materials and workmanship.

Furthermore, EPA and California regulations require all manufacturers to furnish written instructions describing how to operate and maintain the engines/equipment including the emission control systems. This information is provided with all Wacker Neuson engines/equipment at the time of purchase.

Exhaust Emissions

The combustion process produces carbon monoxide, oxides of nitrogen, and hydrocarbons. Control of hydrocarbons and oxides of nitrogen is very important because, under certain conditions, they react to form photochemical smog when subjected to sunlight. Carbon monoxide does not react in the same way, but it is toxic.

Wacker Neuson utilizes lean carburetor settings and other systems to reduce the emissions of carbon monoxide, oxides of nitrogen, and hydrocarbons.

Evaporative Emissions

Evaporative emissions are fuel emissions and generally include emissions that result from permeation of fuel through the fuel-system materials or from ventilation of the fuel system.

Wacker Neuson utilizes low-permeation fuel lines and fuel tanks where applicable to reduce evaporative emissions.

Problems that may affect Emissions

If any of the following symptoms arise, have the engine/equipment inspected and repaired by a Wacker Neuson dealer/service center.

- Hard starting or stalling after starting
 - Rough idling
 - Misfiring or backfiring under load
 - Afterburning (backfiring)
 - Presence of black exhaust smoke during operation
 - High fuel consumption
-

Emission Control Systems Information and Warranty

Tampering and Altering

Tampering with or altering the emission control system may increase emissions beyond the legal limit. If evidence of tampering is found, Wacker Neuson may deny a warranty claim. Among those acts that constitute tampering are:

- Removing or altering of any part of the air intake, fuel, or exhaust systems.
- Altering or defeating the speed-adjusting mechanism causing the engine to operate outside its design parameters.

1.2 Limited Defect Warranty for Wacker Neuson Emission Control Systems

The Emission Control Warranty is valid only for the U.S.A., its territories, and Canada.

Wacker Neuson Sales Americas, LLC, N92 W15000 Anthony Avenue, Menomonee Falls, WI 53051, (hereinafter “Wacker Neuson”) warrants to the initial retail purchaser, and each subsequent owner, that this engine/equipment, including all parts of its emission control systems, have been designed, built, and equipped to conform at the time of initial sale to all applicable emission regulations of the U.S. Environmental Protection Agency (EPA), and that the engine/equipment is free of defects in materials and workmanship which would cause this engine/equipment to fail to conform to EPA regulations during its warranty period.

Wacker Neuson is also liable for damages to other engine/equipment components caused by a failure of any warranted parts during the warranty period.

Limited Defect Warranty Period for Wacker Neuson Emission Control Systems

The warranty period for this engine/equipment begins on the date of sale to the initial purchaser and continues for a minimum of two (2) years. For the warranty terms for your specific engine/equipment, visit wackerneuson.com.

Any implied warranties are limited to the duration of this written warranty.

What is covered

Wacker Neuson recommends the use of genuine Wacker Neuson parts, or the equivalent, whenever maintenance is performed. The use of replacement parts not equivalent to the original parts may impair the effectiveness of the engine/equipment emission controls systems. If such a replacement part is used in the repair or maintenance of the engine/equipment, assure yourself that such part is warranted by its manufacturer to be equivalent to the parts offered by Wacker Neuson in performance and durability. Furthermore, if such a replacement part is used in the repair or maintenance of the engine/equipment, and an authorized Wacker Neuson dealer/service center determines it is defective or causes a failure of a warranted part, the claim for repair of the engine/equipment may be denied. If the part in question is not related to the reason the engine/equipment requires repair, the claim will not be denied.

For the components listed in the following table, an authorized Wacker Neuson dealer/service center will, at no cost to you, make the necessary diagnosis, repair, or replacement necessary to ensure that the engine/equipment complies with the

Emission Control Systems Information and Warranty

applicable EPA regulations. All defective parts replaced under this warranty become property of Wacker Neuson.

Exhaust Emissions

Systems Covered	Components
Fuel metering system	Carburetor and internal parts
	Air/fuel ratio feedback system (if applicable)
	Cold start enrichment system (if applicable)
	Regulator assembly (if applicable)
Exhaust system	Catalytic muffler (if applicable)
	Exhaust manifold (if applicable)
Air induction system	Air filter housing
	Air filter element*
	Intake manifold (if applicable)
Ignition system	Flywheel magneto
	Ignition module
	Electronic controls (if applicable)
	Spark advance/retard system (if applicable)
	Spark plug cap
	Spark plug*
Miscellaneous parts associated with the exhaust emission control system	Tubing
	Fittings
	Seals
	Gaskets
	Clamps

* Indicates expendable maintenance items. Warranted only to first scheduled replacement point.

Evaporative Emissions

Systems Covered	Components
Evaporative control system	Fuel tank (if applicable)
	Fuel tank cap (if applicable)
	Fuel line (if applicable)
	Fuel line fittings (if applicable)
	Clamps (if applicable)
	Carbon canister (if applicable)
	Purge port connector (if applicable)
Miscellaneous parts associated with the evaporative emission control system	Clamps
	Gaskets
	Mounting brackets

Emission Control Systems Information and Warranty

What is not covered

- Failures other than those resulting from defects in material or workmanship.
 - Any systems or parts which are affected or damaged by owner abuse, tampering, neglect, improper maintenance, misuse, improper fueling, improper storage, accident and/or collision; the incorporation of, or any use of, add-on or modified parts, or unsuitable attachments, or the alteration of any part.
 - Replacement of expendable maintenance items made in connection with required maintenance services after the item's first scheduled replacement as listed in the maintenance section of the engine/equipment operator's manual, such as spark plugs and filters.
 - Incidental or consequential damages such as loss of time or the use of the engine/equipment, or any commercial loss due to the failure of the engine/equipment.
 - Diagnosis and inspection charges that do not result in warranty-eligible service being performed.
 - Any non-authorized replacement part, or malfunction of authorized parts due to use of non-authorized parts.
-

Owner's Warranty Responsibility

The engine/equipment owner is responsible for the performance of the required maintenance listed in the Wacker Neuson engine/equipment operator's manual. Wacker Neuson recommends that all receipts covering maintenance on the engine/equipment be retained, but Wacker Neuson cannot deny warranty coverage solely for the lack of receipts or for the failure to ensure the performance of all scheduled maintenance.

Normal maintenance, replacement, or repair of emission control devices and systems may be performed by any repair establishment or individual; however, warranty repairs must be performed by an authorized Wacker Neuson dealer/service center.

The engine/equipment must be presented to an authorized Wacker Neuson dealer/service center as soon as a problem exists. Contact Wacker Neuson Product Support Department (1-800-770-0957) or visit wackerneuson.com to find a dealer/service center in your area, or to answer questions regarding warranty rights and responsibilities.

How to Make a Claim

In the event that any emission-related part is found to be defective during the warranty period, you shall notify Wacker Neuson Product Support Department (1-800-770-0957), and you will be advised of the appropriate dealer/service center where warranty repair can be performed. All repairs qualifying under this limited warranty must be performed by an authorized Wacker Neuson dealer/service center.

You must take your Wacker Neuson engine/equipment along with proof of original purchase date, at your expense, to the authorized Wacker Neuson dealer/service center during their normal business hours.

Emission Control Systems Information and Warranty

For owners located more than 100 miles from an authorized dealer/service center (excluding the states with high-altitude areas as identified in 40 CFR Part 1068, Appendix III), Wacker Neuson will pay for pre-approved shipping costs to and from an authorized Wacker Neuson dealer/service center.

Claims for repair or adjustment found to be caused solely by defects in material or workmanship will not be denied because the engine/equipment was not properly maintained and used.

The warranty repairs should be completed in a reasonable amount of time, not to exceed 30 days.



2. Safety Information

This manual contains DANGER, WARNING, CAUTION, *NOTICE*, and NOTE signal words which must be followed to reduce the possibility of personal injury, damage to the equipment, or improper service.



This is the safety alert symbol. It is used to alert you to potential personal injury hazards. Obey all safety messages that follow this symbol to avoid possible injury or death.



DANGER

DANGER indicates a hazardous situation which, if not avoided, will result in death or serious injury.



WARNING

WARNING indicates a hazardous situation which, if not avoided, could result in death or serious injury.



CAUTION

CAUTION indicates a hazardous situation which, if not avoided, could result in minor or moderate injury.

NOTICE: Used without the safety alert symbol, **NOTICE** indicates a situation which, if not avoided, could result in property damage.

Note: *Contains additional information important to a procedure.*

2.1 Laws Pertaining to Spark Arresters

Notice: State Health Safety Codes and Public Resources Codes specify that in certain locations spark arresters be used on internal combustion engines that use hydrocarbon fuels. A spark arrester is a device designed to prevent accidental discharge of sparks or flames from the engine exhaust. Spark arresters are qualified and rated by the United States Forest Service for this purpose.

In order to comply with local laws regarding spark arresters, consult the engine distributor or the local Health and Safety Administrator.

2.2 Operating Safety



WARNING

Familiarity and proper training are required for the safe operation of the machine. Machines operated improperly or by untrained personnel can be hazardous. Read the operating instructions contained in this manual and the engine manual, and familiarize yourself with the location and proper use of all controls. Inexperienced operators should receive instruction from someone familiar with the machine before being allowed to operate it.

- 2.2.1 Do not allow anyone to operate this equipment without proper training. People operating this equipment must be familiar with the risks and hazards associated with it.
- 2.2.2 Do not touch the engine or muffler while the engine is on or immediately after it has been turned off. These areas get hot and may cause burns.
- 2.2.3 Do not use accessories or attachments that are not recommended by Wacker Neuson. Damage to equipment and injury to the user may result.
- 2.2.4 NEVER operate the machine with the beltguard missing. Exposed drive belt and pulleys create potentially dangerous hazards that can cause serious injuries.
- 2.2.5 Never leave the machine running unattended.
- 2.2.6 Be sure operator is familiar with proper safety precautions and operation techniques before using machine.
- 2.2.7 Always wear protective clothing appropriate to the job site when operating the machine.
- 2.2.8 Wear hearing protection when operating equipment.
- 2.2.9 Close fuel valve on engines equipped with one when machine is not being operated.
- 2.2.10 Store the machine properly when it is not being used. The machine should be stored in a clean, dry location out of the reach of children.
- 2.2.11 Always operate machine with all safety devices and guards in place and in working order. Do not modify or defeat safety devices. Do not operate machine if any safety devices or guards are missing or inoperative.
- 2.2.12 Read, understand, and follow procedures in the Operator's Manual before attempting to operate the machine.

2.3 Operator Safety while using Internal Combustion Engines



Internal combustion engines present special hazards during operation and fueling. Read and follow the warning instructions in the engine owner's manual and the safety guidelines below. Failure to follow the warnings and safety standards could result in severe injury or death.

- 2.3.1 DO NOT run the machine indoors or in an enclosed area such as a deep trench unless adequate ventilation, through such items as exhaust fans or hoses, is provided. Exhaust gas from the engine contains poisonous carbon monoxide gas; exposure to carbon monoxide can cause loss of consciousness and may lead to death.
- 2.3.2 Do not smoke while operating the machine.
- 2.3.3 Do not smoke when refueling the engine.
- 2.3.4 Do not refuel a hot or running engine.
- 2.3.5 Do not refuel the engine near an open flame.
- 2.3.6 Do not spill fuel when refueling the engine.
- 2.3.7 Do not run the engine near open flames.
- 2.3.8 Refill the fuel tank in a well-ventilated area.
- 2.3.9 Replace the fuel tank cap after refueling.
- 2.3.10 ALWAYS check the fuel lines and the fuel tank for leaks and cracks before starting the engine. Do not run the machine if fuel leaks are present or the fuel lines are loose.

2.4 Service Safety



A poorly maintained machine can become a safety hazard! In order for the machine to operate safely and properly over a long period of time, periodic maintenance and occasional repairs are necessary.





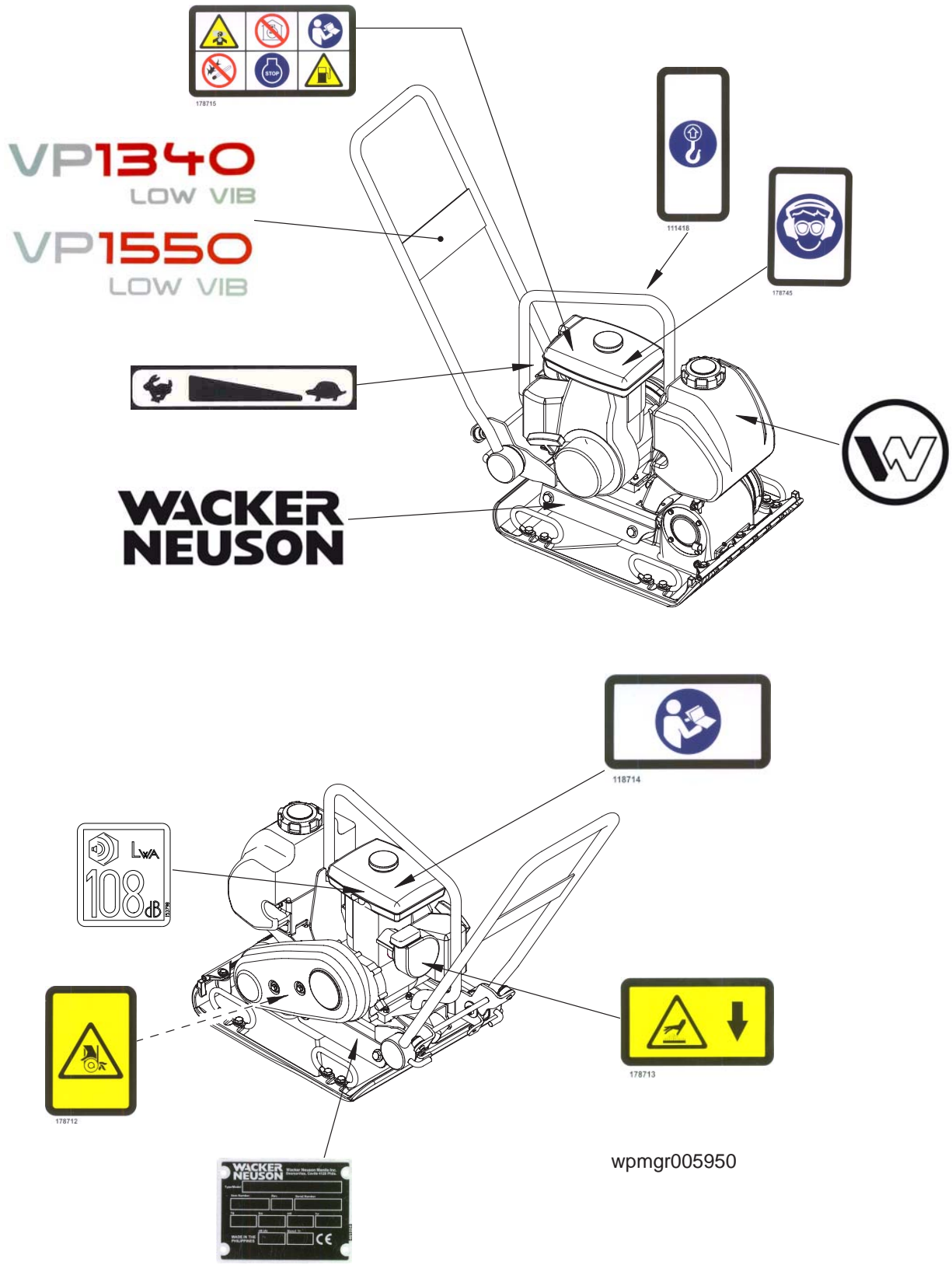

- 2.4.1 Do not attempt to clean or service the machine while it is running. Rotating parts can cause severe injury.
- 2.4.2 Do not crank a flooded engine with the spark plug removed on gasoline-powered engines. Fuel trapped in the cylinder will squirt out the spark plug opening.
- 2.4.3 Do not test for spark on gasoline-powered engines if the engine is flooded or the smell of gasoline is present. A stray spark could ignite the fumes.
- 2.4.4 Do not use gasoline or other types of fuels or flammable solvents to clean parts, especially in enclosed areas. Fumes from fuels and solvents can become explosive.
- 2.4.5 Keep the area around the muffler free of debris such as leaves, paper, cartons, etc. A hot muffler could ignite the debris and start a fire.
- 2.4.6 Replace worn or damaged components with spare parts designed and approved by Wacker Neuson.
- 2.4.7 Disconnect the spark plug on machines equipped with gasoline engines, before servicing, to avoid accidental start-up.
- 2.4.8 Keep the machine clean and labels legible. Replace all missing and hard-to-read labels. Labels provide important operating instructions and warn of dangers and hazards.





2.5 Label Locations

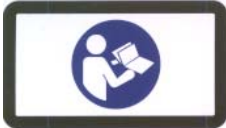

2.6 Warning and Informational Labels

Wacker Neuson machines use international pictorial labels where needed. These labels are described below.

Label	Meaning
 <p>178745</p>	<p>WARNING! Always wear hearing and eye protection when operating this machine.</p>
 <p>178713</p>	<p>WARNING! Hot surface</p>
	<p>Guaranteed sound power level in dB(A).</p>
 <p>178712</p>	<p>WARNING! Hand injury if caught in moving belt. Always replace beltguard.</p>
 <p>118714</p>	<p>CAUTION! Read and understand the supplied Operator's Manual before operating this machine. Failure to do so increases the risk of injury to yourself and others.</p>
 <p>111418</p>	<p>NOTICE Lifting point.</p>

Label	Meaning
	<p>Throttle control lever: Turtle = Idle or Slow Rabbit = Full or Fast</p>
 <p>178715</p>	<p>DANGER! Engines emit carbon monoxide; operate only in well-ventilated area. Read the Operator's Manual. No sparks, flames, or burning objects near the machine. Shut off the engine before refueling.</p>
<p>VP1340 LOW VIB</p> <p>VP1550 LOW VIB</p>	<p>Label-machine model</p>
	<p>Company logo</p>
<p>WACKER NEUSON</p>	<p>Company label</p>
	<p>A nameplate listing the model number, item number, revision number, and serial number is attached to each unit. Please record the information found on this nameplate so it will be available should the nameplate become lost or damaged. When ordering parts or requesting service information, you will always be asked to specify the model number, item number, revision number, and serial number of the unit.</p>

Label	Meaning
<p>U.S. PAT. Nos.: OTHER U.S. AND FOREIGN PATENTS PENDING</p>	<p>This machine may be covered by one or more patents.</p>

3. Technical Data

3.1 Engine Data

Engine Power Rating

Net power rating per SAE J1349. Actual power output may vary due to conditions of specific use.

		VP 1340, VP 1340 W 0008705, 0008706 VP 1550, VP 1550 W 0008707, 0008708 VP 1550 W 0630013	VP 1340 W-L 0630001 VP 1340 W-LL 0630002 VP 1340 W-LF 0630003
Engine			
Engine Make		Wacker	
Engine Model		WM170	
Max. rated power @ rated speed	kW (Hp)	4.2 (5.7) @ 4000 rpm	
Operating speed	rpm	3600	
Clutch Engagement	rpm	2100	
Spark Plug		NGK BR6HS Champion RL86C	
Electrode Gap	mm (in.)	0.6-0.7 (0.02–0.03)	
Air Cleaner	type	Dual element type, Urethane foam and paper element	
Engine Lubrication	oil grade	SAE 10W30 SE or higher	
Engine Oil Capacity	ml (oz.)	600 (20)	
Fuel	type	Regular unleaded gasoline	
Fuel Tank Capacity	l (qts.)	3.6 (3.8)	
Valve Clearance (cold) Inlet: Outlet:	mm (in.)	0.07-0.13 (0.003-0.005) 0.17-0.23 (0.007-0.009)	

3.2 Machine Data

		VP 1340, VP 1340 W 0008705, 0008706 VP 1340W - L 0630001 VP 1340W - LL 0630002 VP 1340W - LF 0630003	VP 1550, VP 1550 W 0008707, 0008708 VP 1550 W 0630013
Plate			
Weight	kg (lbs.)	VP 1340: 74 (163) VP 1340W: 76 (168) VP 1340W-L: 76 (168) VP 1340W-LL: 76 (168) VP 1340W-LF: 76 (168)	VP 1550: 83 (184) VP 1550W: 86 (190)
Water Tank Capacity	l (qts.)	3.8 (4.0)	7.6 (8.0)
Exciter Speed	rpm	5800 ± 100	
Exciter Lubrication	ml (oz.)	240 (8) Automatic transmission fluid Dextron III/Mercon or equivalent	

3.3 Sound and Vibration Measurements

The required sound specification, Paragraph 1.7.4.f of 89/392/EEC Machinery Directive, is:

- the guaranteed sound power level (L_{WA}) = 108 dB(A).
- the sound pressure level at operator’s location (L_{pA}):

VP 1340 = 90 dB(A), VP 1550 = 91 dB(A).

These sound values were determined according to ISO 3744 for the sound power level (L_{WA}) and ISO 6081 for the sound pressure level (L_{pA}) at the operator’s location.

The weighted effective acceleration value, determined according to EN ISO 5349, is approximately = 4.5 m/s².

The sound and vibration measurements were obtained with the machine operating on crushed gravel at nominal engine speed.

3.4 Dimensions

mm (in.)

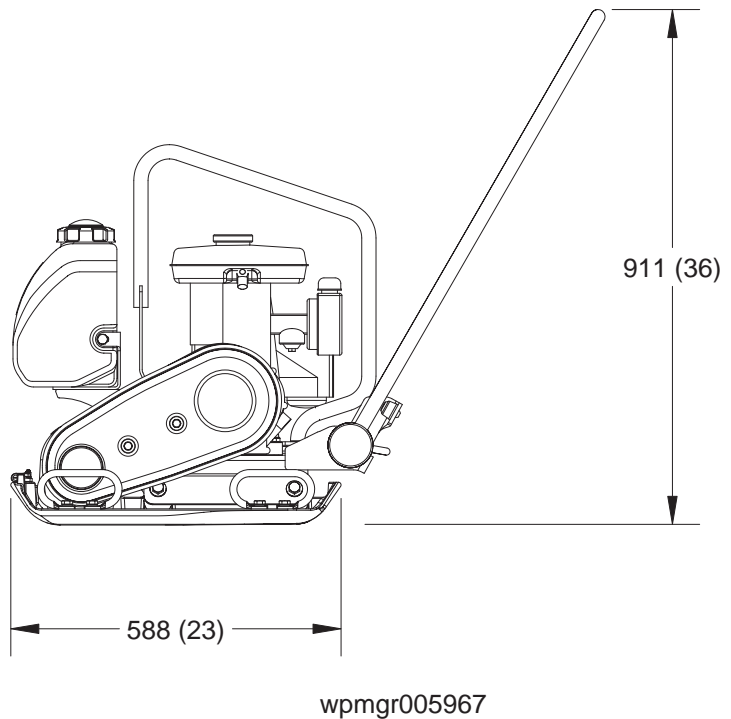
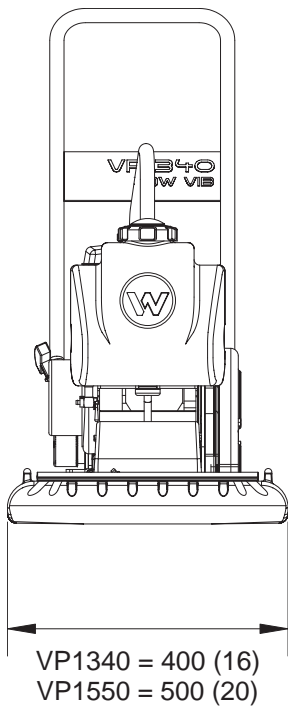

4. Operation

4.1 Recommended Fuel

The engine requires regular grade unleaded gasoline. Use only fresh, clean gasoline. Gasoline containing water or dirt will damage fuel system. Consult engine owner's manual for complete fuel specifications.

Use of oxygenated fuels

Some conventional gasolines are blended with alcohol. These gasolines are collectively referred to as oxygenated fuels. If you use an oxygenated fuel, be sure it is unleaded and meets the minimum octane rating requirement.

Before using an oxygenated fuel, confirm the fuel's contents. Some states / Provinces require this information to be posted on the fuel pump.

The following are Wacker Neuson approved percentages of oxygenates:

ETHANOL - (ethyl or grain alcohol) 10% by volume. You may use gasoline containing up to 10% ethanol by volume (commonly referred to as E10). Gasoline containing more than 10% ethanol (such as E15, E20, or E85) may not be used because it could damage the engine.

METHANOL - (methyl or wood alcohol) 5% by volume. You may use gasoline containing up to 5% methanol by volume, as long as it contains cosolvents and corrosion inhibitors to protect the fuel system. Gasoline containing more than 5% methanol by volume may cause starting and/or performance problems. It may also damage metal, rubber, and plastic parts of your fuel system.

If you notice any undesirable operating symptoms, try another service station, or switch to another brand of gasoline.

Fuel system damage or performance problems resulting from the use of an oxygenated fuel containing more than the percentages of oxygenates mentioned above are not covered under warranty.

4.2 Application

This plate is designed for compacting loose, granular soils, gravel, and paving stones. It is intended to be used in confined areas and areas next to structures such as walls, curbs, and foundations. Plates equipped with water tanks can be used for compacting asphalt.

This plate is not recommended for compacting cohesive soils with a heavy clay content. For cohesive soil, use a vibratory rammer or sheepsfoot roller.

4.3 Before Starting

4.3.1 Read and understand the safety and operating instructions at the beginning of this manual.

4.3.2 Check:

- Oil level in the engine
- Fuel level
- Condition of the air cleaner
- Tightness of the external fasteners
- Condition of the fuel lines

4.4 To Start

See Graphic: wc_gr000655

4.4.1 Open fuel valve by moving lever down (a1).

Note: If engine is cold, move choke lever to close position (d2). If engine is hot, set choke to open position (d1).

4.4.2 Turn engine switch to “ON” (b2).

4.4.3 Open throttle by moving it slightly to left (c2).

4.4.4 Pull starter rope (e).

Note: If the oil level in the engine is low, the engine will not start. If this happens, add oil to engine.

4.4.5 Open choke as engine warms (d1).

4.4.6 Open throttle fully to operate (c1).

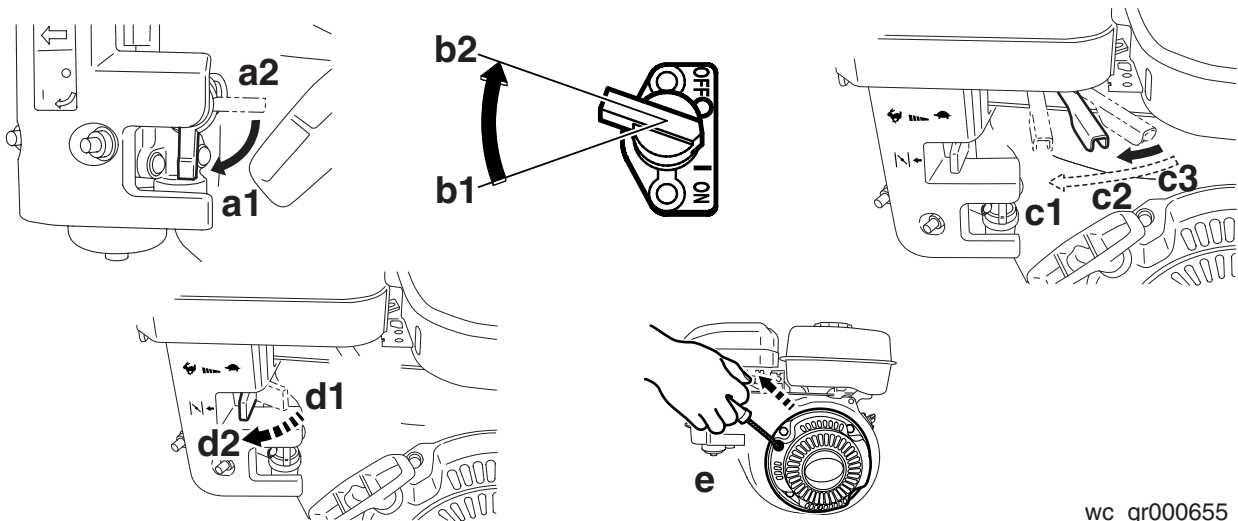

wc_gr000655

4.5 To Stop

See Graphic: wc_gr000655

4.5.1 Reduce engine RPM to idle by moving throttle completely to right (c3).

4.5.2 Turn engine switch to “OFF” (b1).

4.5.3 Close fuel valve (a2).

4.6 Operation

Run the engine at full throttle and allow the plate to pull itself along at its normal speed. When operating on an incline it may be necessary to assist the plate by pushing it forward slightly. When operating downhill hold the plate back slightly, if it begins to pick up speed. Depending on the material being compacted, three or four passes are recommended to achieve the best compaction.

While a certain amount of moisture in the soil is necessary, excessive moisture may cause soil particles to stick together and prevent good compaction. If soil is extremely wet, allow it to dry somewhat before compacting.

If soil is so dry as to create dust clouds while operating plate, some moisture should be added to the ground material to improve compaction. This will also reduce service to the air filter.

For compacting asphalt, use a water tank to wet the asphalt and the underside of plate. This will prevent asphalt material from sticking. Two passes are usually sufficient to ensure good compaction.

When using the plate on paving stones, attach a pad to the bottom of the plate to prevent chipping or grinding surface of stones. A special polyurethane pad designed for this purpose is available as an optional accessory.

NOTICE: DO NOT operate the plate on concrete or on extremely hard, dry, compacted surfaces. The plate will jump rather than vibrate and could damage both the plate and the engine.

4.6.1

5. Maintenance

5.1 Maintaining the Emission Control System

Normal maintenance, replacement or repair of emission control devices and systems may be performed by any repair establishment or individual; however, warranty repairs must be performed by a dealer/service center authorized by WACKER NEUSON. The use of service parts that are not equivalent in performance and durability to authorized parts may impair the effectiveness of the emission control system and may have a bearing on the outcome of a warranty claim.

5.2 Periodic Maintenance Schedule

5.2.1 Engine Maintenance

The chart below lists basic engine maintenance. Refer to the engine manufacturer’s Operation Manual for additional information.

	Daily before starting	After first 20 hrs.	Every 2 weeks or 50 hrs.	Every month or 100 hrs.	Every year or 300 hrs.
Check fuel level.	■				
Check engine oil level.	■				
Inspect fuel lines.	■				
Inspect air filter. Replace as needed.	■				
Clean air cleaner elements.			■		
Change engine oil.		■		■	
Clean engine cooling fins.				■	
Clean sediment cup / fuel filter.				■	
Check and clean spark plug.				■	
Check and adjust valve clearance.					■
Change exciter oil.					■

Machine Maintenance

The chart below lists basic machine maintenance.

	Daily before starting	After first 20 hrs.	Every 2 weeks or 50 hrs.	Every month or 100 hrs.	Every year or 300 hrs.
Check external hardware.	■				
Check and adjust drive belt.		■	■		
Inspect shockmounts for damage.			■		
Replace shockmounts as needed.					■
Change exciter oil.					■



Note: *When machine is being used in asphalt, it is highly recommended that shockmounts are replaced every year or after 300 hours of usage.*

5.3 Spark Plug

See Graphic: *wc_gr000028*

Clean or replace the spark plug as needed to ensure proper operation. Refer to your engine operator's manual.



WARNING

The muffler becomes very hot during operation and remains hot for a while after stopping the engine. Do not touch the muffler while it is hot.

Note: Refer to section "Technical Data" for the recommended spark plug type and the electrode gap setting.

- 5.3.1 Remove the spark plug and inspect it.
- 5.3.2 Replace the spark plug if the insulator is cracked or chipped.
- 5.3.3 Clean the spark plug electrodes with a wire brush.
- 5.3.4 Set the electrode gap (**a**).
- 5.3.5 Tighten the spark plug securely.

NOTICE: A loose spark plug can become very hot and may cause engine damage.

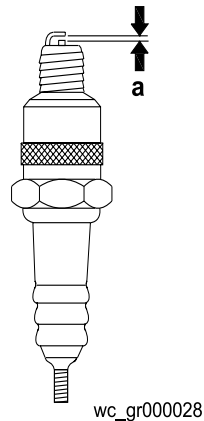

5.4 Air Cleaner

See Graphic: wc_gr000656



WARNING

NEVER use gasoline or other types of low-flash point solvents for cleaning the air cleaner. A fire or explosion could result.

NOTICE: NEVER run the engine without the air cleaner. Severe engine damage will occur.

The engine is equipped with a dual-element air cleaner. Under normal operating conditions, the elements should be cleaned once every week. Under severe, dry and dusty conditions, the elements should be maintained daily. Replace an element when it is saturated with dirt that cannot be removed.

- 5.4.1 Remove the air cleaner cover (**a**). Remove the filter assembly by pulling it straight up. Inspect both elements for holes or tears. Replace damaged elements.
- 5.4.2 Wash the foam element (**b**) in a solution of mild detergent and warm water. Rinse it thoroughly in clean water. Allow the element to dry thoroughly.
- 5.4.3 Tap the paper element (**c**) lightly to remove excess dirt or blow compressed air through the filter from the inside out. Replace the paper element if it appears heavily soiled.

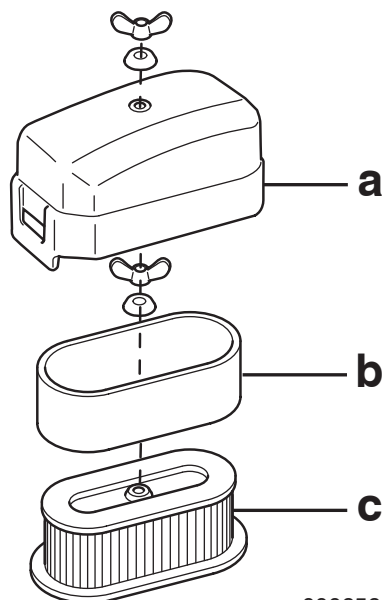

wc_gr000656

5.5 Engine Oil

See Graphic: *wc_gr000087*

5.5.1 Drain oil while engine is still warm.

Note: *In the interests of environmental protection, place a plastic sheet and a container under the machine to collect any liquid which drains off. Dispose of this liquid in accordance with environmental protection legislation.*

5.5.2 Remove the oil drain plug (a).

5.5.3 Allow the oil to drain.

5.5.4 Install the drain plug.

5.5.5 Fill the engine crankcase through the oil filler opening (b), to the upper mark on the dipstick (c). Do not thread in the dipstick to check the level. See *Technical Data* for oil quantity and type.

5.5.6 When the crankcase is full, reinstall the dipstick.

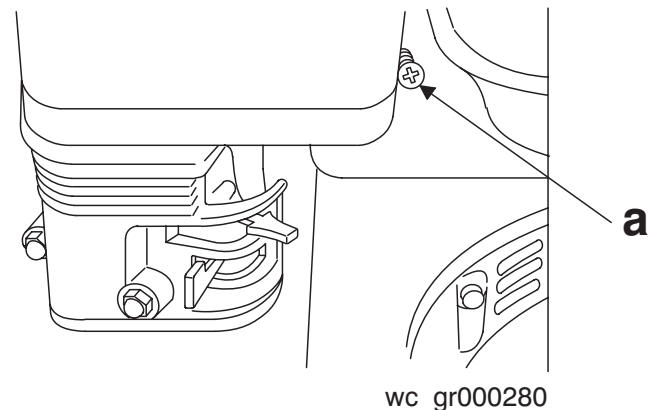
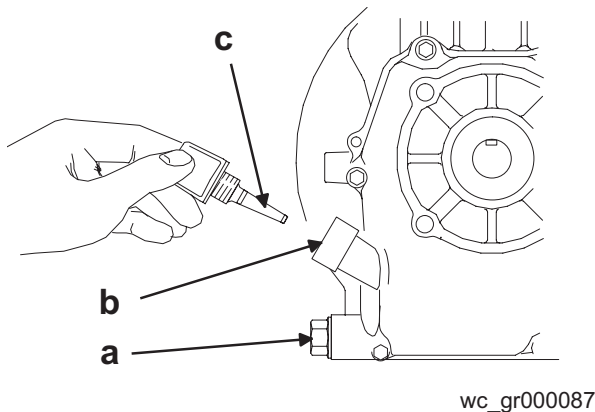

5.6 Adjusting Engine Speed

See Graphic: *wc_gr000280*

Adjust to a full load speed of 3600 ± 100 rpm.

To adjust engine speed:

5.6.1 Place machine on a rubber test mat to prevent it from moving.

5.6.2 Start engine and allow it to warm up for a minute.

5.6.3 Turn throttle stop screw (a) in to increase speed, out to decrease speed. Make sure throttle lever is touching stop screw before measuring RPM.

NOTICE: Running plate at a speed higher than that listed in *Technical Data* can damage both the plate and the engine.

5.7 Cleaning the Fuel Strainer

- 5.7.1 To remove water and dirt, close the fuel lever and remove the fuel strainer.
- 5.7.2 Inspect the fuel strainer (**a**) for water and dirt.
- 5.7.3 After removing any dirt and water, wash the fuel cup with a nonflammable solvent.
- 5.7.4 Reinstall securely to prevent leakage.

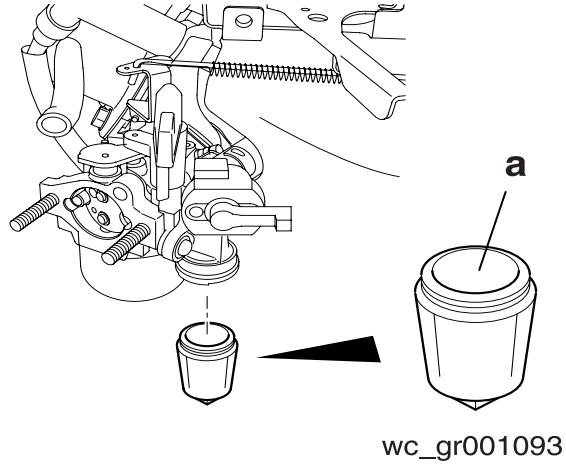

5.8 Drive Belt

See Graphic: *wpmgr005993*

On new machines or after installing a new belt, check the belt tension after first 20 hours of operation. Check and adjust the belt every 50 hours thereafter.

To adjust the belt:

- 5.8.1 Loosen the two screws **(a)** on the beltguard, then remove the beltguard, keeping the screw assemblies captured on the beltguard.
- 5.8.2 Loosen the four nuts **(b)** which hold the engine to the console, and the screw **(c)** which holds the beltguard back to the console.
- 5.8.3 Slide the engine backward (towards the handle) to tighten the belt, forward to loosen the belt.
- 5.8.4 Adjust the belt so that it deflects 10–13 mm **(d)** when pressed midway between the belt pulleys.
- 5.8.5 Make sure that the clutch pulley **(f)** and the exciter pulley **(e)** are in alignment. Place a straight edge against the exciter pulley **(e)** and move the engine so that the two pulleys are parallel.
- 5.8.6 Torque all nuts and screws to 20.5 Nm as you reassemble the machine.

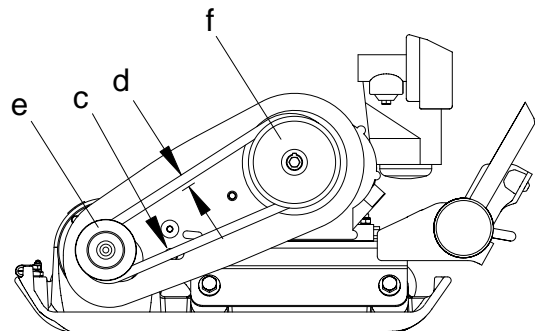
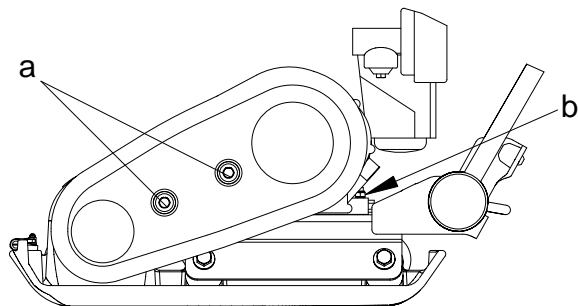

wpmgr005993

5.9 Exciter Lubrication

See Graphic: *wpmgr006018*

The bearings in the exciter assembly are splash lubricated and rotate at very high speed. It is important to maintain the exciter oil at the correct level and change it regularly.

Check oil level in exciter every 50 hours of operation.

To check oil level, place plate on a flat, level surface. Remove the drain plug (a) with seal ring (b). Oil level should be at drain plug threads. Add oil as required.

Change exciter oil every 300 hours of operation.

To drain oil, remove plug (a) from end of exciter and tilt plate up.

Note: In the interests of environmental protection, place a plastic sheet and a container under the machine to collect any liquid which drains off. Dispose of this liquid in accordance with environmental protection legislation.

Place plate on a level surface and add oil through plug opening until oil reaches the drain plug threads. See *Technical Data*.

NOTICE: DO NOT overfill. Too much oil in the exciter can reduce performance and damage the drive belt.

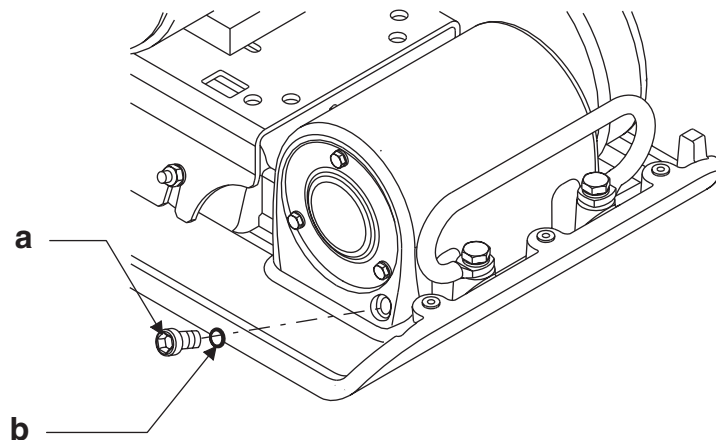

wpmgr006018

5.10 Cleaning Plate

Clean plate after use to remove dirt, stones, and mud caught under the engine console. If plate is being used in a dusty area, check engine cylinder cooling fins for heavy dirt accumulation. Keep engine cylinder fins clean to prevent engine from overheating.

5.11 Lifting Machine

See Graphic: wpmgr006023

See *Technical Data* for weight of the machine.

To lift machine manually:

- 5.11.1 Stop the engine.
- 5.11.2 Obtain help from a partner and plan the lift.



WARNING

To avoid burns or fire hazards, let the engine cool before transporting the machine or storing it indoors. Turn the fuel valve to the off position and keep the engine level to prevent fuel from spilling.

- 5.11.3 Grasp machine by the lifting handles **(a)** and **(b)**.

Note: On the VP1340, the left front lifting handle (a) is not present. Grasp lifting handle (b) with both hands.

- 5.11.4 Lift machine as shown.



WARNING

To reduce risk of back injury while lifting, keep feet flat on ground and shoulder width apart. Keep head up and back straight.

To lift machine mechanically:

NOTICE: Before attempting to lift, be sure that lifting devices can safely handle weight of the machine. See *Technical Data* for weight of the machine.

- 5.11.5 Attach hook, harness, or cable to machine as shown **(c)**, and lift as desired.

NOTICE: DO NOT lift the vibroplate by its guide handle. The vibroplate can shift, causing it to fall.

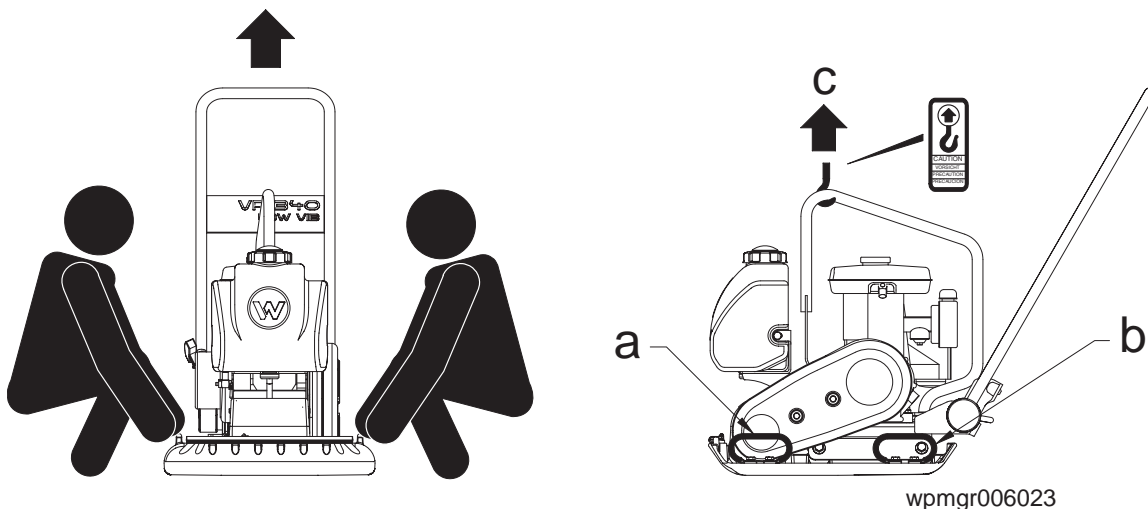

wpmgr006023

5.12 Transporting Machine

See Graphic: *wpmgr006043*



WARNING

To avoid burns or fire hazards, let engine cool before transporting machine or storing indoors.

- 5.12.1 Turn fuel valve to the off position and keep the engine level to prevent fuel from spilling.
- 5.12.2 Tie down machine on vehicle to prevent machine from sliding or tipping over. Tie machine to vehicle at points shown on graphic.

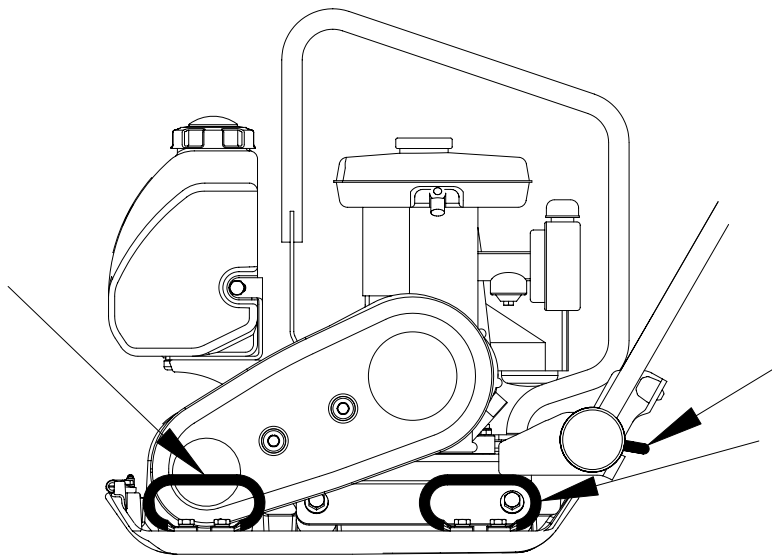

wpmgr006043

5.13 Storage

If plate is being stored for more than 30 days:

- 5.13.1 Remove loose stones and dirt from plate.
- 5.13.2 Clean engine cylinder cooling fins.
- 5.13.3 Clean or replace air filter.
- 5.13.4 Change exciter oil.
- 5.13.5 Change engine oil and follow procedures described in engine manual for engine storage.
- 5.13.6 Cover plate and engine and store in a clean, dry area.

5.14 Troubleshooting

Problem / Symptom	Reason / Remedy
Plate does not develop full speed. Poor compaction.	<ul style="list-style-type: none"> • Engine throttle control not completely open. • Throttle control not adjusted correctly. • Ground too wet, plate sticking. Allow soil to dry before compacting. • Drive belt loose or worn, slipping on pulleys. Adjust or replace belt. Check that engine mounting bolts are tight. • Exciter bearings binding. Check condition and level of oil in exciter. Add or change oil. • Air filter clogged with dust, reducing engine performance. Clean or replace air filter. • Engine speed too low. Check engine speed with tachometer. Adjust or repair engine to run at correct speed. Refer to engine manual.
Engine running, no vibration	<ul style="list-style-type: none"> • Engine throttle not open. • Drive belt loose or broken. Adjust or replace. • Clutch damaged. Inspect and replace clutch. • Engine speed too low. Check engine speed. • Too much oil in exciter. Adjust oil to correct level.
Plate jumps or compacts unevenly.	<ul style="list-style-type: none"> • Ground surface too hard. • Shockmounts loose or damaged.



EC Declaration of Conformity

Manufacturer

Wacker Neuson Manila, Inc. Dasmariñas, Cavite, Philippines

Product

Product	VP 1340, VP 1340W, VP 1340W-L, VP 1340W-LL, VP 1340 W-LF, VP 1550, VP 1550W
Product category	Vibrating plate
Product function	Compacting soils
Item number	0630050, 0630051, 0630001, 0630002, 0630003, 0630052, 0630053
Net installed power	4.2 kW
Measured sound power level	100 dB(A)
Guaranteed sound power level	105 dB(A)

Conformity assessment procedure

According to 2000/14/EC, Appendix VI, 2005/88/EC.

Notified body

VDE Prüf- und Zertifizierungsinstitut GmbH, Merianstraße 28, 63069 Offenbach/Main

Directives and standards

We hereby declare that this product meets and complies with the relevant regulations and requirements of the following directives and standards:

2006/42/EG, 2000/14/EG, 2005/88/EG

Authorized person for technical documents

Axel Häret,
Wacker Neuson Produktion GmbH & Co. KG, Preußenstraße 41, 80809 München

Philippines, 08.04.2013

Heinz Gengnagel
President & CEO

Wacker Neuson SE, Preußenstraße 41, D-80809 München, Tel.: +49-(0)89-3 54 02-0 Fax: +49 - (0)89-3 54 02-390

Wacker Neuson Production Americas LLC, N92W15000 Anthony Ave., Menomonee Falls, WI 53051

Tel.: (262) 255-0500 Fax: (262) 255-0550 Tel.: (800) 770-0957

Wacker Neuson Limited - Room 1701-03 & 1717-20, 17/F. Tower 1, Grand Century Place, 193 Prince Edward Road West, Mongkok, Kowloon, Hongkong.
Tel: (852) 3605 5360, Fax: (852) 2758 0032